

CASUN Intelligent Robot GmbH  
Suzhou CASUN Intelligent Robot Co., Ltd.

# PRODUCT CATALOG

stock code . 834863

**CASUN Intelligent Robot GmbH**  
**Suzhou CASUN Intelligent Robot Co., Ltd.**

Germany office: Spaldingstr.210, 4.Stock, 20097 Hamburg, Germany Tel: 040 228515982

China headquarter: Building 1, Miaquan Industrial Park, Guli Town, Changshu City, Suzhou City, Jiangsu Province

400-700-6846

+86-512 52868698

vip@casun99.com

www.casun-agv.com



Intelligent logistics project solution



Intelligent control system



Mobile robot

**casun**  
佳顺智能

# CATALOGUE



## 01 ABOUT CASUN

01 / 06

Company profile	/01
Core business	/03
Service network	/05

## 02 Mobile robot

07 / 54

C1-Latent traction series	/07
C2-Latent lift series	/19
C3-Unit load AGV with conveyor series	/31
C5-Intelligent forklift mobile robot series	/39
CCM-Customization series	/47
CCS-Charging Station Series	/53

## 03 Intelligent system

55 / 64

Mobile Robot Control System	/55
Intelligent Warehouse Management System	/57
Intelligent Warehouse Equipment Control System	/59
Intelligent Warehouse Sorting System	/61
Digital simulation system	/63

## 04 PROJECT SOLUTION

65 / 76

New energy lithium battery	/65
New energy photovoltaic	/67
Automobile and parts	/69
Flat panel display	/71
3C & Semiconductor	/73
Logistics and transportation	/75

## 05 Enterprise service

77 / 78

Service Concept	/77
Service Item	/77
Service Process	/78
Follow Us	/78

# 5<sup>+</sup>

Compatible with 5-generation navigation mode Visual navigation + Cluster scheduling

# 5<sup>+</sup>

5+ series mobile robot It covers the whole scene of manufacturing and intelligent logistics

# 8<sup>+</sup>

Cover all kinds of application scenarios. 8 series, more than 50 models

# 16<sup>+</sup>

**Founded in 2007**  
Focus in AGV industries for 16 years

# 50<sup>+</sup>

The business network covers the worldwide 28 subsidiaries, offices and 30+ global agents

# 2800<sup>+</sup>

More than 2800 system solutions have been completed and delivered

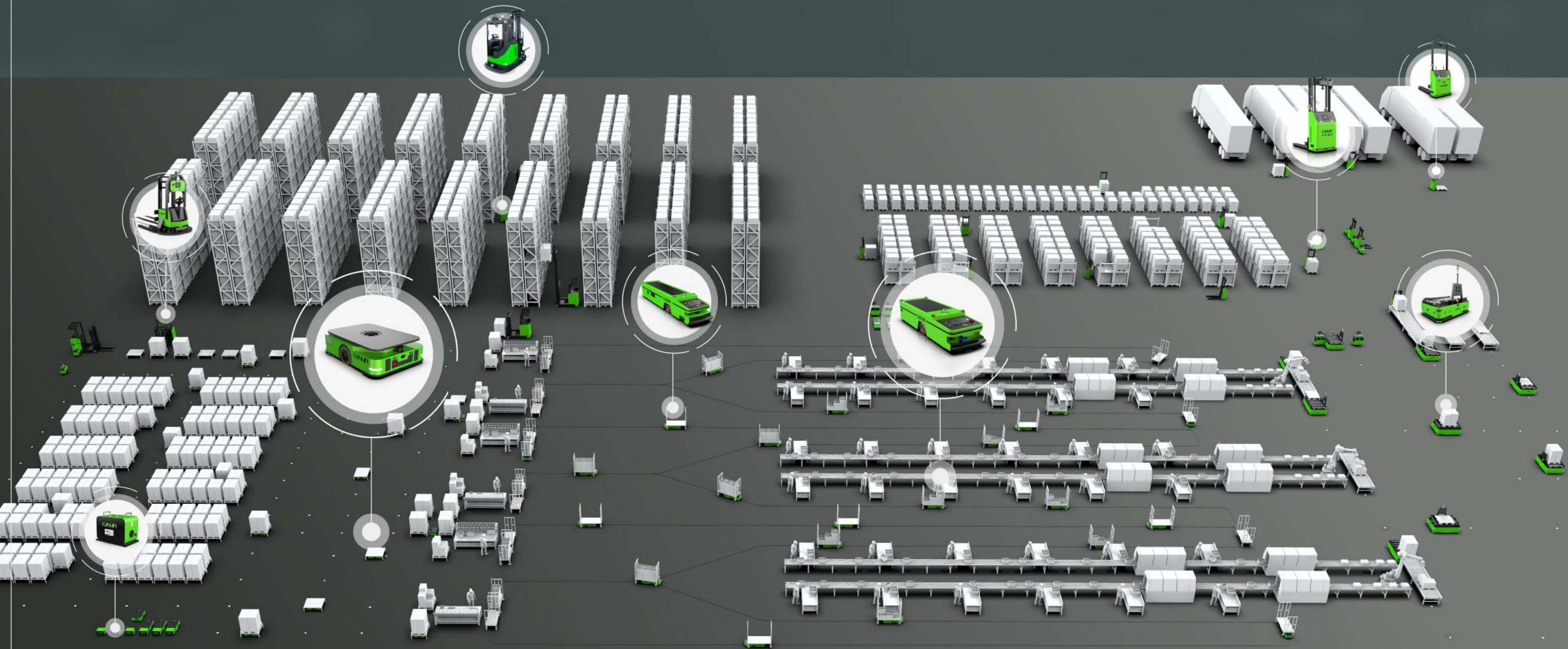

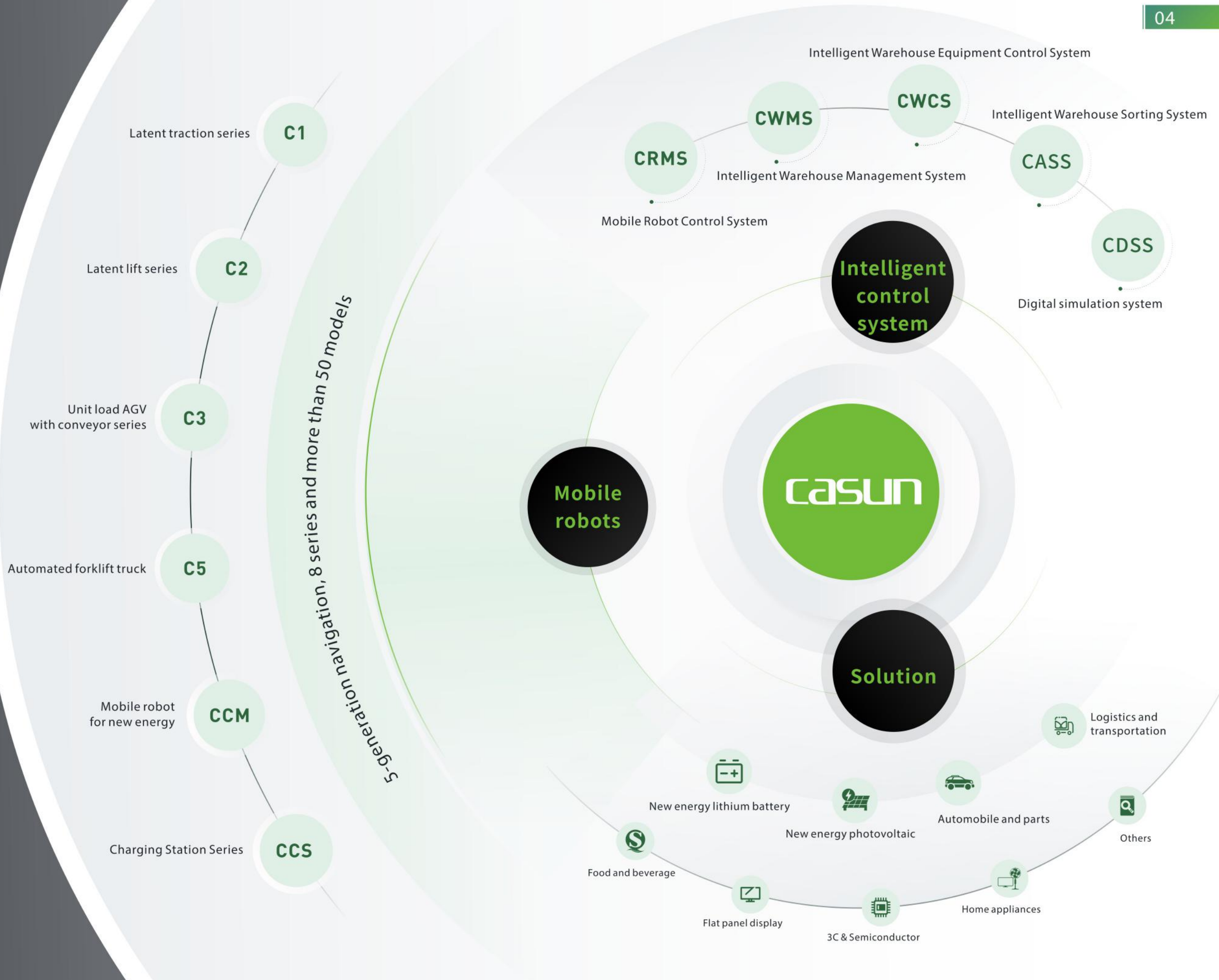



Serving  
The  
Globe

**5** R&D centers



Suzhou Shenzhen Shanghai Chengdu Xi'an

**28** Service network  
Headquarter: Suzhou, Shenzhen

Changshu, Wuxi, Nanjing, Changzhou, Hefei, Nantong, Shanghai, Ningbo, Guangzhou, Huizhou, Foshan, Dongguan, Zhuhai, Fuzhou, Wuhan, Zhengzhou, Changsha, Nanchang, Chengdu, Chongqing, Qingdao, Xi'an, Beijing, Tianjin, Urumqi, Shenyang

**30<sup>+</sup>** Global Agent

USA, Mexico, Brazil, Chile, UK, Ireland, Germany, France, Czech Republic, Ukraine, Romania, Turkey, Russia, South Africa, India, Vietnam, Thailand, Malaysia, Singapore, Indonesia, Philippines, South Korea, Japan, Australia, Taiwan, Hong Kong, China...

# C1

## — Latent Traction Series Mobile Robots



Series Introduction

Latent traction series mobile robots can lurk under the material truck, use the traction rod to automatically lift, hook or drop the material vehicle. This series of products are divided into one-way, two-way and omni-directional according to the running direction, the navigation method is magnetic navigation, and the traction capacity is 500kg~1500kg. Latent traction series AGVs are widely used, compact in structure, flexible in operation, mature and stable, and suitable for various material vehicles.



Application Environment

-10°C ~ 45°C; no dust, flammable, explosive and corrosive gases.



Model	C1-11B	C1-12	C1-14	C1-22	C1-24	
						
Basic Parameters	Dimension	L1400*W420*H290 mm	L1900*W420*H328 mm	L1965*W420*H328 mm	L1900*W420*H290 mm	L1900*W420*H290 mm
	Max payload	500kg / 1000kg	1000kg / 1500kg	1500kg	1000kg / 1500kg	1000kg
	Weight	180kg	220kg	220kg	280kg	362kg
	Turning radius	650mm	1200mm	1500mm	1000mm	1000mm
Navigation Performance	Navigation mode	Magnetic navigation	Magnetic navigation	SLAM	Magnetic navigation	SLAM
	Navigation accuracy	±10mm	±10mm	±10mm	±10mm	±10mm
	Stop accuracy	±10mm	±10mm	±5mm	±10mm	±10mm
Movement Performance	Moving direction	Forward, turn left and right	Forward, turn left and right	Forward, turn left and right	Forward, backward, turn left and right	Forward, backward, turn left and right
	Drive mode	Differential drive	Differential drive	Differential drive	Differential drive	Differential drive
	Acceleration	0.2m/s <sup>2</sup>	0.2m/s <sup>2</sup>	0.2m/s <sup>2</sup>	0.2m/s <sup>2</sup>	0.2m/s <sup>2</sup>
	Max moving speed	45m/min	45m/min	45m/min	35m/min	35m/min
	Max climbing capability	≤3°	≤3°	≤3°	≤3°	≤3°
Battery Performance	Battery type	Lithium battery	Lithium battery	Lithium battery	Lithium battery	Lithium battery
	Charging mode	Side charge/ Ground charge	Side charge/ Ground charge	Ground charging	Side charge/ Ground charge	Ground charging
	Charging time	1H	1H	1H	1H	1H
	Rated endurance	8H	8H	8H	8H	8H
Network	Communication	RF / WiFi / 5G	RF / WiFi / 5G	WiFi / 5G	RF / WiFi / 5G	WiFi / 5G
Protective Performance	Safety warning	· Light warning · Voice broadcast	· Light warning · Voice broadcast	· Light warning · Voice broadcast	· Light warning · Voice broadcast	· Light warning · Voice broadcast
	Safe sensing range	≤3m adjustable	≤3m adjustable	≤3m adjustable	≤3m adjustable	≤3m adjustable
	Safety protection	Obstacle detection sensor ahead Mechanical anti-collision mechanism emergency stop switch	Obstacle detection sensor ahead Mechanical anti-collision mechanism emergency stop switch	Obstacle detection sensor ahead Mechanical anti-collision mechanism emergency stop switch	Front and rear obstacle detection sensor Mechanical anti-collision mechanism emergency stop switch	Front and rear obstacle detection sensor Mechanical anti-collision mechanism emergency stop switch



# C1-11B

Automobile and Parts Industry · Flexible Production Line ▶

## Product introduction

C1-11B one-way latent traction AGV is suitable for workshops with relatively fixed production processes. The working method is that the AGV automatically lurks to the bottom of the material truck after receiving system instructions, and automatically connects to the material vehicle through the AGV traction rod to realize material handling. End-to-end transfer. At present, it has been widely used in the two application scenarios of SPS material supply in automobile assembly workshop and PACK line in new energy lithium battery industry.

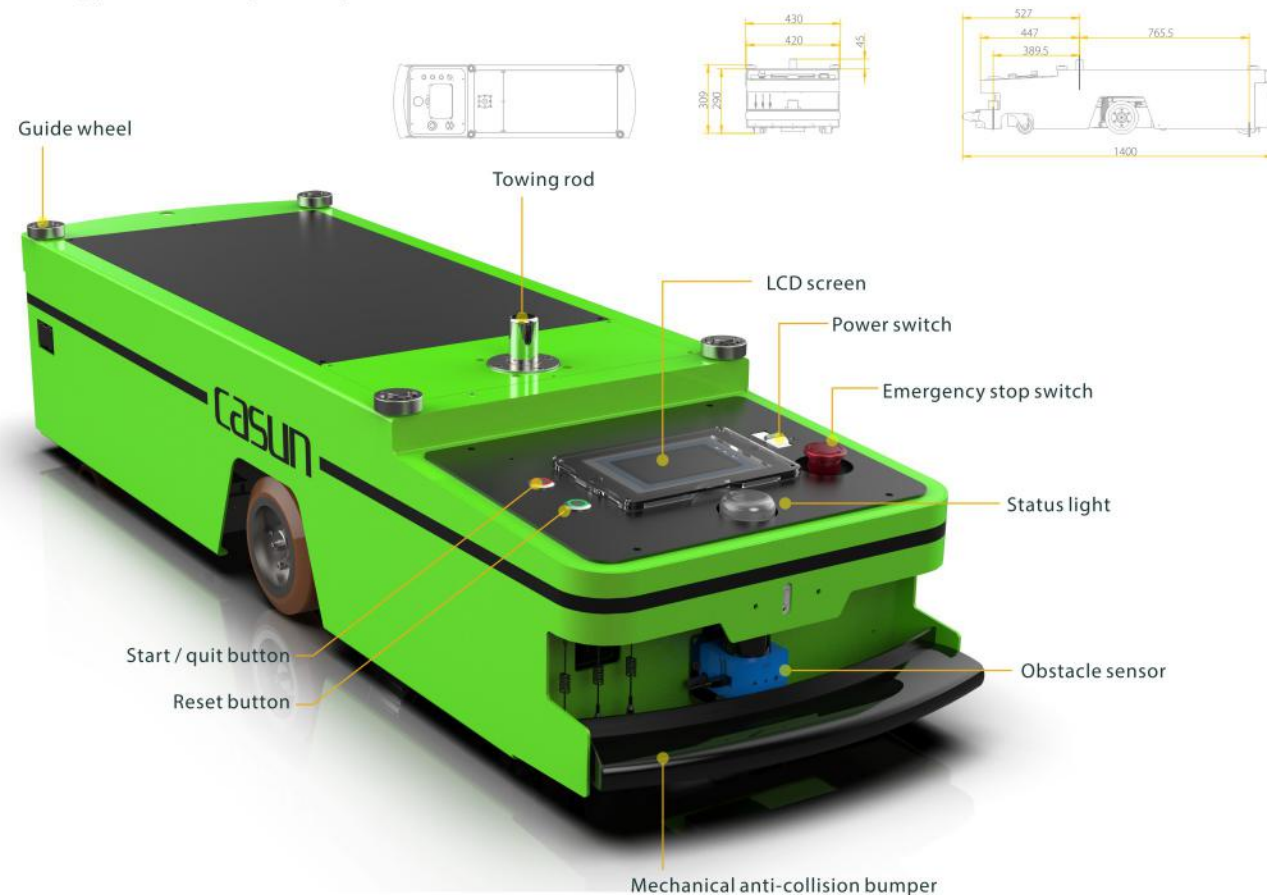

## Product advantages

 The product performance is stable, and there are a large number of mature application cases;

 The car body is flexible and the turning radius is small;

 High cost performance and short delivery period;

 Flexible production to ensure smooth production lines;

## Application industries and scenarios

### application industry

Automobiles and parts, new energy lithium batteries, machinery manufacturing, electronics, electrical appliances and other diversified industries;

### application scenarios

Transportation of production line materials, raw materials, parts and components, forming a flexible production line, etc.;

## Project case - Automobile assembly workshop project

### Solution

In the final assembly line and the instrument line, workers stand on the side of the line and operate on the special material truck pulled by the AGV. After completing the current process, they are released to the next station to realize streamlined operation. By replacing the original fixed production line, flexible production is realized, which is also conducive to later expansion and upgrading, and reduces the cost of later line body transformation; through the application of AGV in each link, the entire logistics link is connected in series to realize unmanned Smart delivery.

### Economic benefits

#### Improve operating efficiency

Realize unmanned handling through AGV, saving warehouse logistics personnel;

#### Improved management efficiency

The AGV system is connected to the production management system, which can remind warehouse personnel to prepare materials in advance, avoid delays in production line, and significantly save personnel management costs;

#### Reduce errors

Through automatic material calling, point-to-point material handling is realized, and the error rate due to manual distribution is reduced.



CASUN



# C1-12

New energy lithium battery industry PACK line

## Product introduction

C1-12 one-way latent traction type AGV is suitable for workshops with relatively fixed production processes. end-to-end transfer. A flow production line can also be composed of multiple AGVs to realize flexible production in the factory. At present, it is widely used in the PACK line scene of the new energy lithium battery industry.

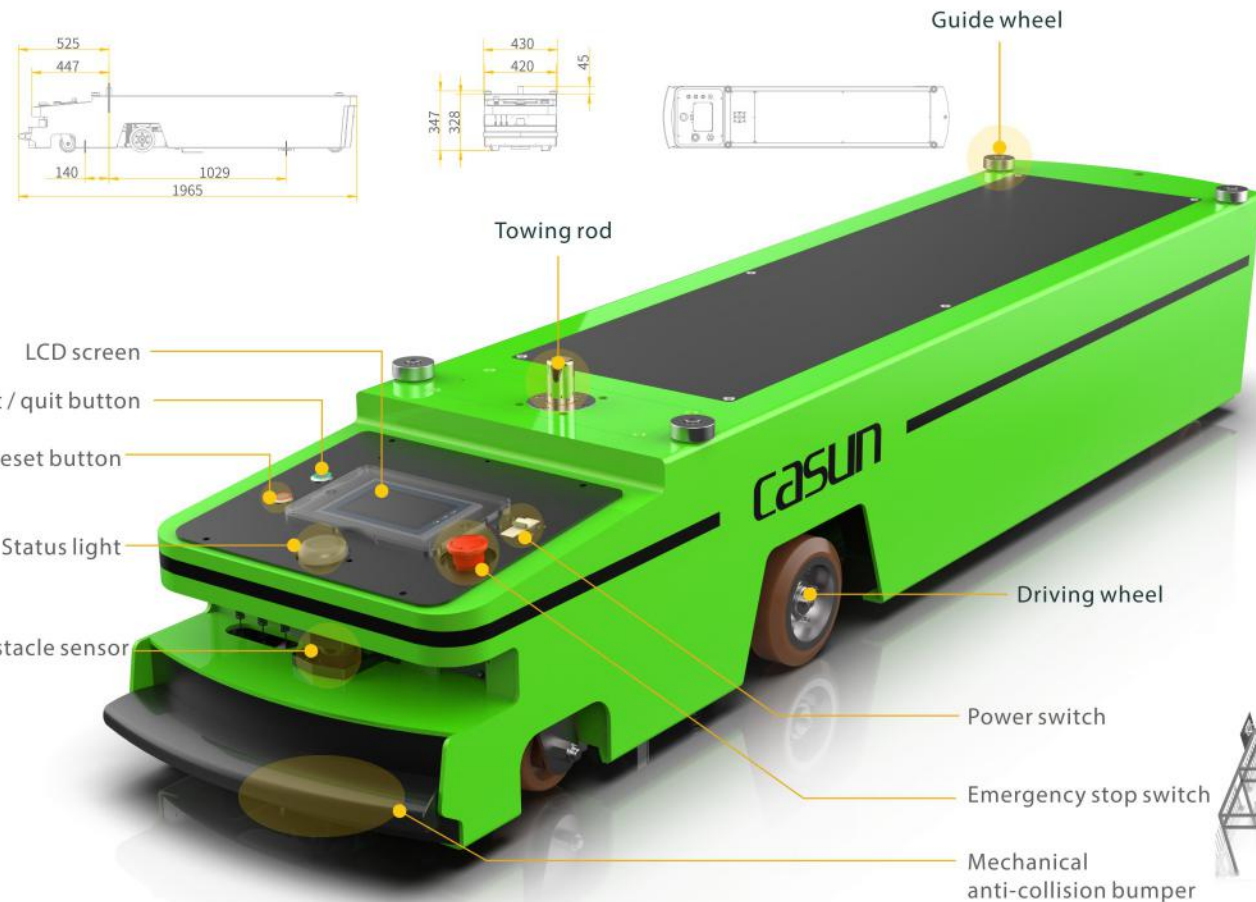

## Product advantages

- Stable performance:** The product performance is stable, and there are a large number of mature application cases;
- Short lead time and high cost performance;**
- Adaptability:** Adapt to the lithium battery industry and the automobile industry;
- Flexibility:** Flexible production to ensure smooth production lines;

## Application industries and scenarios

- Application industry:** Diversified industries such as new energy lithium batteries, automobiles and parts, machinery manufacturing, electronics, and electrical appliances.
- Application scenarios:** End-to-end transportation of production line materials, raw materials and parts, forming a flexible production line, etc.

## Project case - Lithium battery PACK line material transfer project

Solution

The factory's PACK line material transfer project mainly realizes the material transfer between battery packs from assembly to testing to packaging, and its operation process is a circular assembly line. Through the CRMS mobile robot control system, the system realizes autonomous material calling, intelligent handling, information collection, and intelligent storage, and seamlessly connects with the user's production management system.

Difficulties of the project: This project mainly solves the technical difficulties of docking various peripheral equipment systems, such as transmission equipment, robotic arms, etc.; secondly, it accurately realizes the priority logic judgment of AGV operation, according to the sequence of different stations, the CRMS system automatically selects and determines the most suitable transportation route.

Economic benefits

- TQCM:** Create a flexible production line and improve the flexibility of production scheduling.
- Damage reduction:** Reduce damage - improve yield rate and accuracy rate: Reduce material damage during handling, and the defective rate is reduced by 90%.
- Precise location:** The transportation accuracy rate is increased to 99%, which meets the peak demand of full production of the whole line.
- Intelligent logistics:** Realize the optimization of warehouse location, route and task allocation, and the informatization of the whole process.

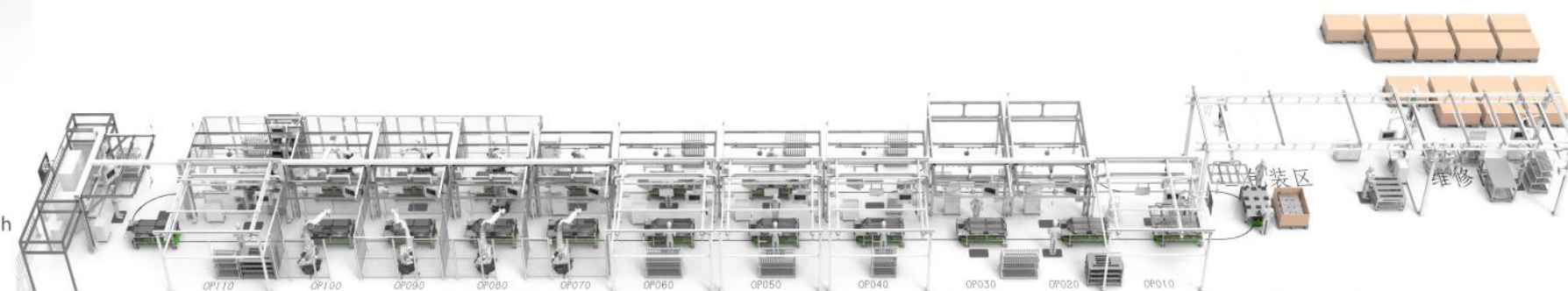





C1-14

Automobile and Parts Industry-Assembly Workshop SPS

### Product introduction

C1-14 one-way latent traction AGV is suitable for sites with relatively fixed environmental contours. The navigation mode is SLAM navigation. The working mode is that the AGV automatically lurks to the bottom of the material truck after receiving system instructions, and is automatically hung by the traction bar. Pick-up trucks realize end-to-end transfer. A flow production line can also be composed of multiple AGVs to realize flexible production in the factory. At present, it is mostly used in SPS of automobile assembly workshop.

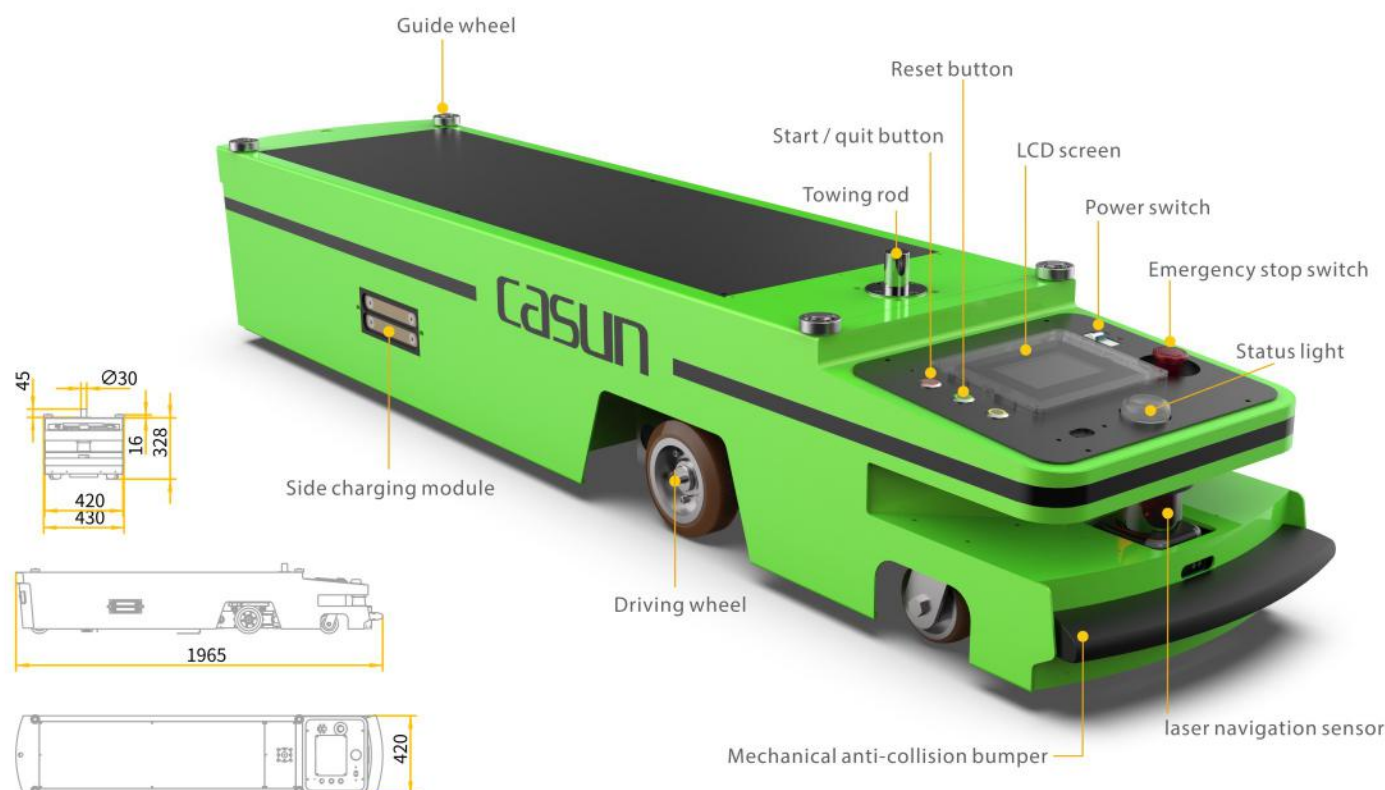

### Product advantages

Adopt advanced SLAM navigation technology;

Adapt to a variety of tooling trucks;

High cost performance and short delivery period;

### Application industries and scenarios

Diversified industries such as automobiles, auto parts, machinery manufacturing, electronics, electrical appliances, and new energy;

Production line materials, raw materials, parts transportation, flexible production lines, etc.

### Project case - SPS distribution of small pieces in the final assembly line

Solution

Small SPS distribution on the final assembly line, mainly including: interior trim line, final line, chassis line, door line, etc., mainly from the material distribution area, small SPS racks are delivered to the edge of the production line, and then through the upper and lower lines. The mechanism is sent to the production line to realize the operation of the SPS material truck along with the production line. It mainly solves the problem of single-set distribution of small materials to the side of the car to run along the line, convenient and fast operation by personnel, space saving in wireless side warehouses, and errors in personnel assembly without errors and missing installations.

Economic benefits

#### Improve efficiency

Improve operating efficiency, realize unmanned handling through AGV, and save warehouse logistics personnel;

#### Space saving

Save storage space at the edge of the production line, and assist customers in realizing 5S management at the edge of the line;

#### Reduce errors

Through automatic material calling, point-to-point material handling is realized, and the error rate due to manual distribution is reduced;



CASE



# C1-22

Automobile and Parts Industry · General Assembly Line ▶

## Product introduction

C1-22 two-way latent traction AGV is suitable for workshops with relatively fixed production processes. The working method is that the AGV automatically lurks to the bottom of the material truck after receiving system instructions, and automatically mounts the material vehicle through the traction rod to realize end-to-end terminal transport. A flow production line can also be composed of multiple AGVs to realize flexible production in the factory. At present, it has been widely used in the automobile and parts industry, new energy lithium battery industry, etc.

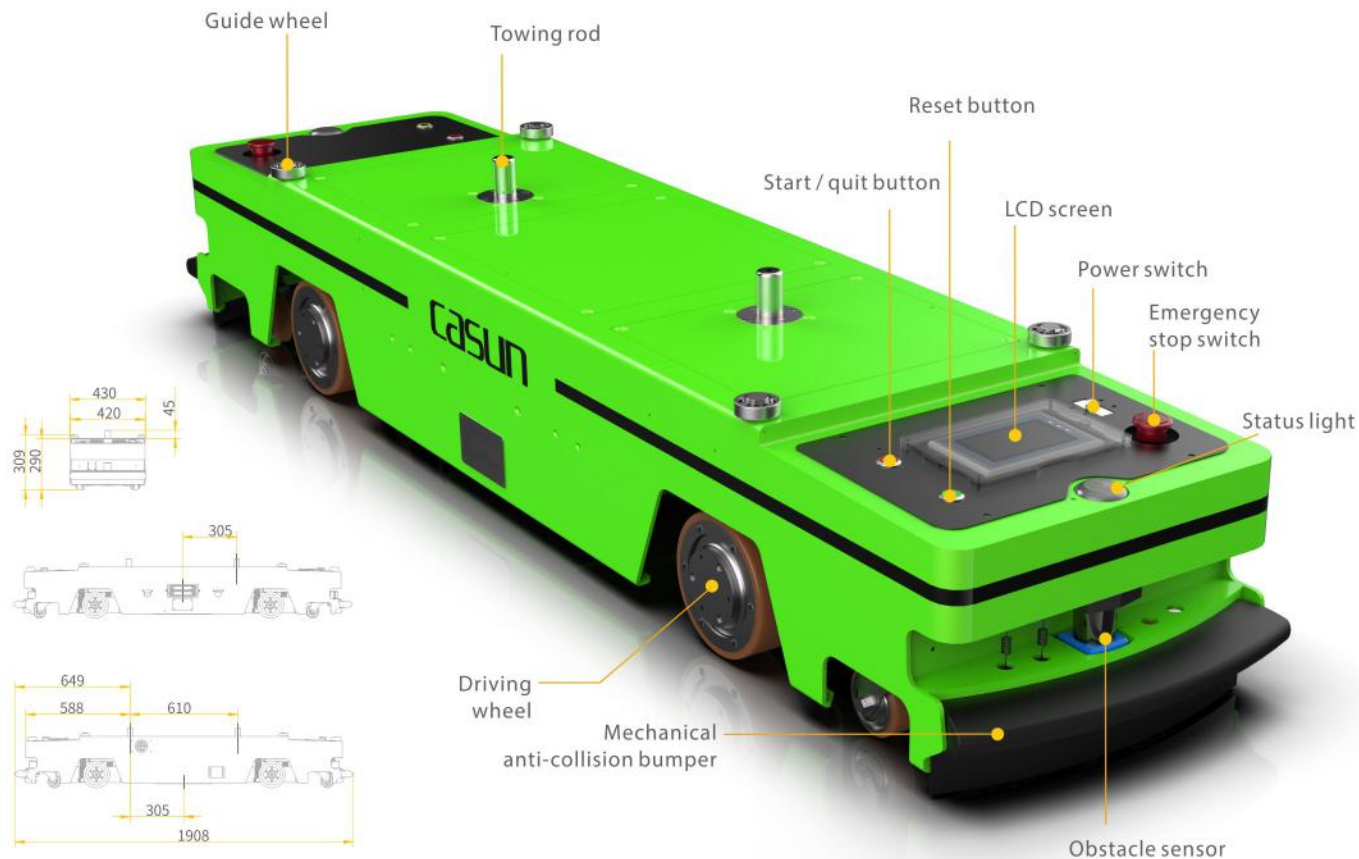

## Product advantages

**△** The product performance is stable, and there are a large number of mature application cases;

**⊗** The car body is flexible and the turning radius is small;

**📍** High cost performance and short delivery period;

**📦** Flexible production to ensure smooth production lines;

## Application industries and scenarios

### 🏭 application industry

Diversified industries such as new energy lithium batteries, automobiles and parts, machinery manufacturing, electronics, and electrical appliances.

### 🔄 application scenarios

Production line materials, raw materials, parts transportation, flexible production lines, etc.

## Project case - Auto parts project

### Solution

Through the two-way AGV, at the site with narrow passages, by switching directions, the exchange of empty and full material trucks can be realized, and the material transfer of raw materials such as exhaust pipes and seats can be realized through special material vehicles, reducing the Materials are piled up at the edge of the production line, rational use of warehouse space, placement of empty and full parts, and increase the number of placements.

### Economic benefits

#### 📈 Improve efficiency

Improve operation efficiency, realize unmanned handling through AGV, and save warehouse logistics personnel;

#### 📦 Space saving

Saving storage space on the production line, assisting customers to realize 5S management on the line;

#### 📍 Automatic material call

Through automatic material call, point-to-point material handling can be realized, and the error rate due to manual distribution can be reduced.



CASE

# C1-24

New energy lithium battery industry PACK line ▶



## Product introduction

C1-24 bidirectional latent traction AGV adopts SLAM navigation or QR code navigation. The working mode is that the AGV automatically lurk to the bottom of the trolley after receiving the system instruction, and automatically hooks the trolley through the traction bar to achieve end-to-end transfer. It can also be composed of multiple AGVs to form a flow production line to achieve flexible production in the factory. At present, it has been widely used in new energy photovoltaic, automobile and parts industry, new energy lithium battery industry.

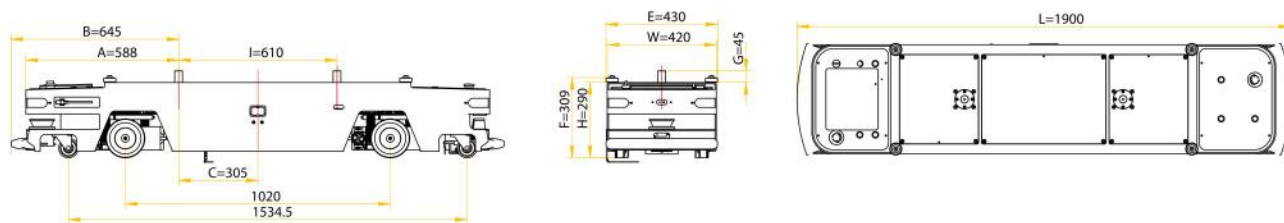

## Product advantages

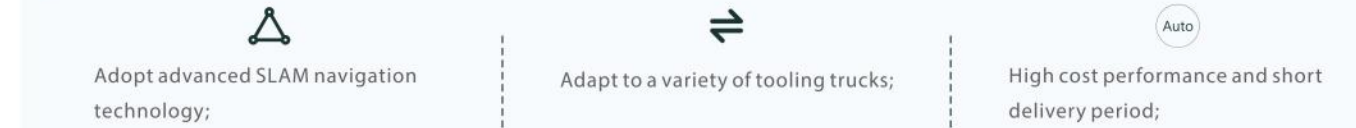

## Application industries and scenarios

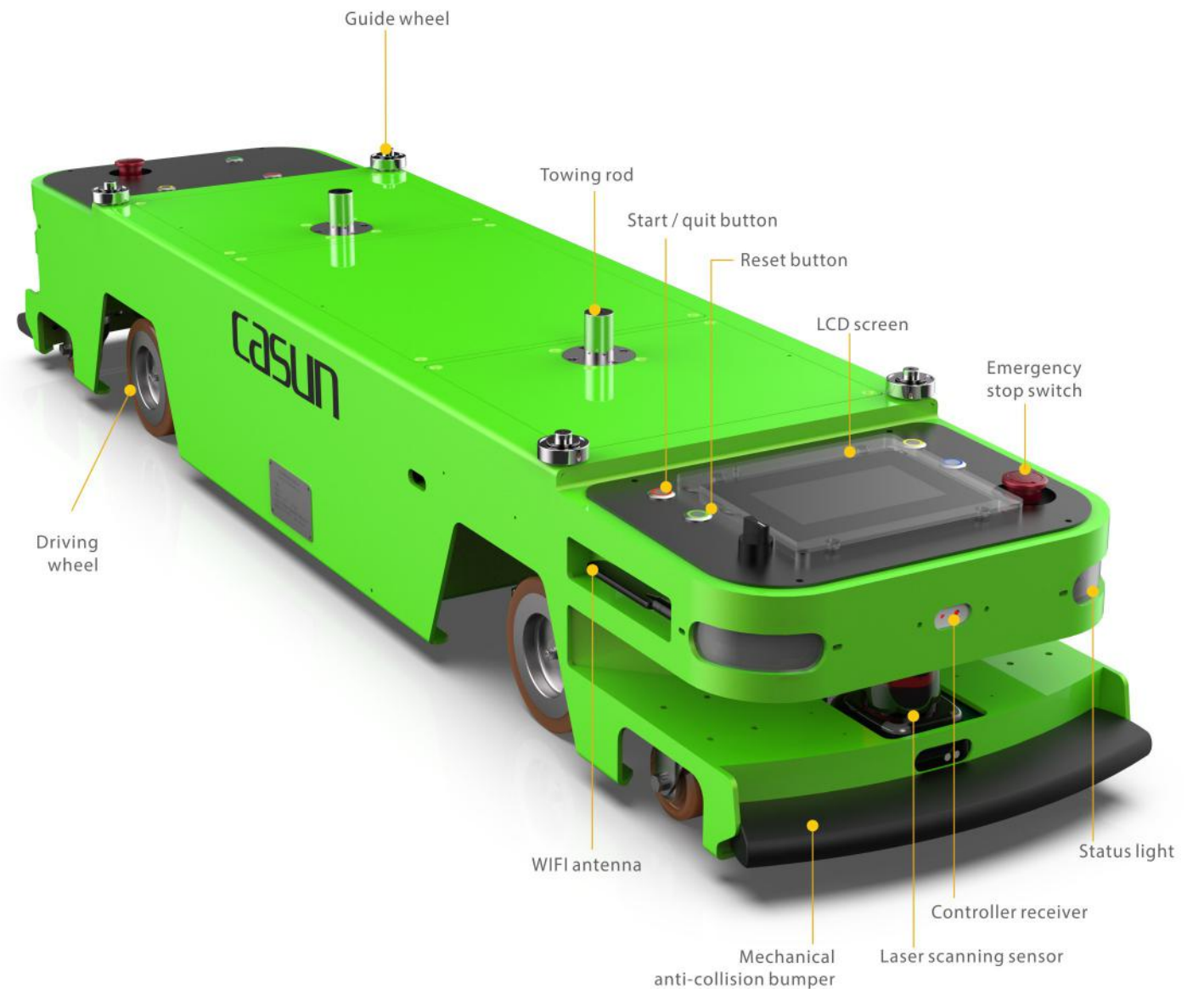

## Latent Lift Mobile Robot

# C2

The latent lifting series mobile robot performs precise positioning according to dispatching instructions, and independently completes lifting, transportation, and unloading operations. It can choose material sorting system, lifting platform, relative rotation of the body and other configurations. The series of products are divided into one-way, two-way and omni-directional according to the running direction, and the navigation method can choose QR code navigation and SLAM navigation. The maximum load can reach 1500kg.



### Series introduction



### Application environment

-10°C ~ 45°C; no dust, flammable, explosive and corrosive gases

Model	C2-22B	C2-23B	C2-26B	C2-36	C2-37	
						
Basic Parameters	Dimension	L940*W650*H253 (mm)	L1180*W860*H300 (mm)	L1600*W860*H350 (mm)	1540*920*370(mm)	L2000*W1000*H840(mm)
	Max Load Capacity	1000kg	1500kg	1500kg	1500kg	1000kg / 1500kg / 2500kg
	Weight	150kg	400kg	400kg	410kg	630kg
	Rotation Diameter	1087mm	1180mm	1770mm	1740mm	2227mm
	Relative Rotation	Yes	Yes	NO	NO	NO
	Size of Lifting Platform	860*600mm	1050*735mm	1280*800mm	1276*796mm	1464*588(mm)
Navigation Performance	Max Lifting Distance	60mm	50mm	60mm	60mm	248mm
	Navigation Mode	QR / SLAM	QR / SLAM	QR	QR / SLAM	QR / SLAM
	Navigation Accuracy	±10mm / ±15mm	±10mm / ±15mm	±10mm	±10mm / ±15mm	±10mm / ±15mm
	Stop Accuracy	±5mm / ±10mm	±5mm / ±10mm	±10mm	±5mm / ±10mm	±5mm / ±10mm
Movement Performance	Stop Angle Accuracy	±1°	±1°	±1°	±1	±1°
	Moving Direction	Forward,Backward,Rotate	Forward,Backward,Rotate	Forward,Backward,Rotate	Forward, backward, sideways, rotating	Forward, backward, sideways, rotating
	Drive Mode	Two-wheel rudder drive	Two-wheel rudder drive	Two-wheel rudder drive	Two-wheel rudder drive	Steering wheel drive
	Accelerated Speed	0.5m/s <sup>2</sup>	0.35m/s <sup>2</sup>	0.35m/s <sup>2</sup>	0.5m/s <sup>2</sup>	0.5m/s <sup>2</sup>
	Max Moving Speed	2m/s	1.2m/s	1.0m/s	1m/s	60m/min
Battery Performance	Max Climbing Capacity	≤3°	≤3°	≤3°	≤3°	≤3°
	Battery	Lithium battery	Lithium battery	Lithium battery	Lithium iron phosphate battery	Lithium battery
	Charging Mode	Collision charging	Collision charging	Side charging	Side charging / ground charging	Side charging/ground charging
	Charging time	Charge time ≤1H after complete discharge	Charge time ≤1H after complete discharge	Charge time ≤1H after complete discharge	Charge time ≤1H after complete discharge	Charge time ≤1H after complete discharge
Network	Rated Duration	4H	6H	6H	4H	6H
	Communication	WiFi / 5G	WiFi / 5G	WiFi / 5G	WiFi / 5G	WiFi / 5G
Protective Performance	Security Alarm	- Light warning - Voice broadcast	- Light warning - Voice broadcast	- Light warning - Voice broadcast	- Light warning - Voice broadcast	- Light warning - Voice broadcast
	Security Sensing Range	≤3m adjustable	≤3m adjustable	≤3m adjustable	≤3m adjustable	≤3m adjustable
	Safety Protection	-Front obstacle detection sensor -Mechanical anti-collision mechanism -Emergency stop switch	-Front and rear obstacle detection sensors -Mechanical anti-collision mechanism -Emergency stop switch	-Front and rear obstacle detection sensors -Mechanical anti-collision mechanism -Emergency stop switch	-Diagonal obstacle sensor, -Mechanical anti-collision mechanism -emergency stop switch	-Front and rear diagonal obstacle detection sensors -Mechanical anti-collision mechanism -Emergency stop switch

# C2-22B

Logistics and Circulation Industry Goods-to-Person Picking



## Product introduction

C2-22B is a latent lifting AGV. It uses trackless navigation and can change the route according to on-site production changes. The model is small and compact, and the load can reach 1000KG after upgrading. The body and the lift plate can be rotated relative to each other. Working method: After the AGV receives the system command, the AGV lurks to the bottom of the material rack, lifts the material rack up, and carries out material transportation; it can also be composed of multiple AGVs to form a mobile production line to achieve flexible production. It has been widely used in automobiles and spare parts Parts industry, photovoltaic industry, 3C and semiconductor industries.



## Product advantages

The body height is smaller, suitable for lower space operation;

It can be used as a flexible production line to ensure smooth production;

Composite navigation can be used, and the docking accuracy is high;

With the function of relative rotation, the flexibility is higher;

## Application industries and scenarios

application industry  
Diversified industries such as photovoltaics, automobiles and parts, logistics and distribution, electronics, and electrical appliances.

application scenarios  
Goods-to-person selection, production line raw materials, end-to-end transportation of parts and components, forming a flexible production line, etc.

## Project case - Automobile back door assembly workshop project

Solution

Through the two-way mobile robot, at the site with narrow passages, the exchange of empty and full material trucks can be realized by switching directions, and the material transfer of raw materials such as exhaust pipes and seats can be realized through special material trucks, reducing the accumulation of materials at the edge of the production line, rationally use the warehouse space, place empty and full materials, and increase the number of placements.

Economic benefits

Flexible production  
Flexible production line, the rate of on-site change is increased, and the incompatibility of the production line caused by changes in production orders is reduced.

TQCM  
Reduce the number of loading and unloading operators and reduce personnel fatigue.

Strong reliability  
Production can still be carried out if a single equipment fails, and the risk of the entire line stopping due to equipment failure at the station is improved.

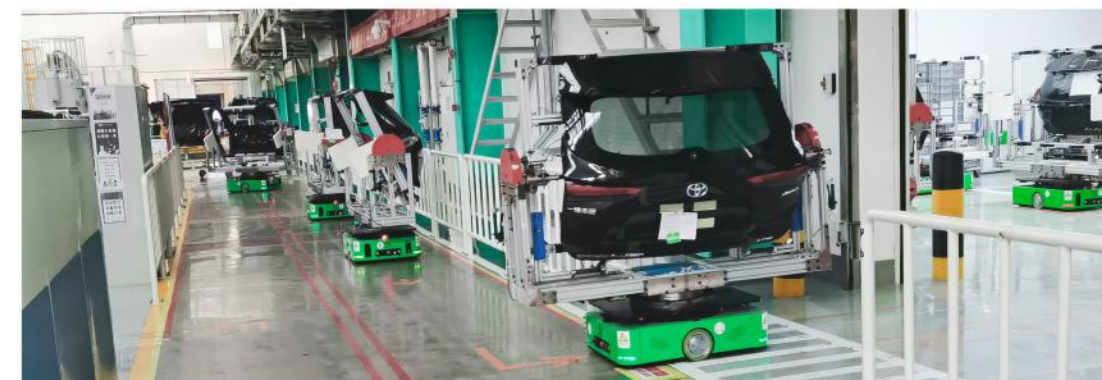

CASUN



# C2-23B

Photovoltaic industry-Sorting of cell raw materials

## Product introduction

C2-23B performs precise positioning according to dispatching tasks, and independently completes a series of operations of lifting, transportation, and unloading. It can choose material sorting system, platform, and body relative rotation configuration, etc. This series is divided into one-way, two-way and omni-directional according to the running direction of the mobile robot. The navigation method can choose QR code navigation and SLAM navigation, and the load capacity can reach 1500kg. At present, it has been widely used in many industries such as new energy photovoltaics, automobiles and parts, logistics and distribution, food and beverage, 3C and semiconductors, and household appliances.

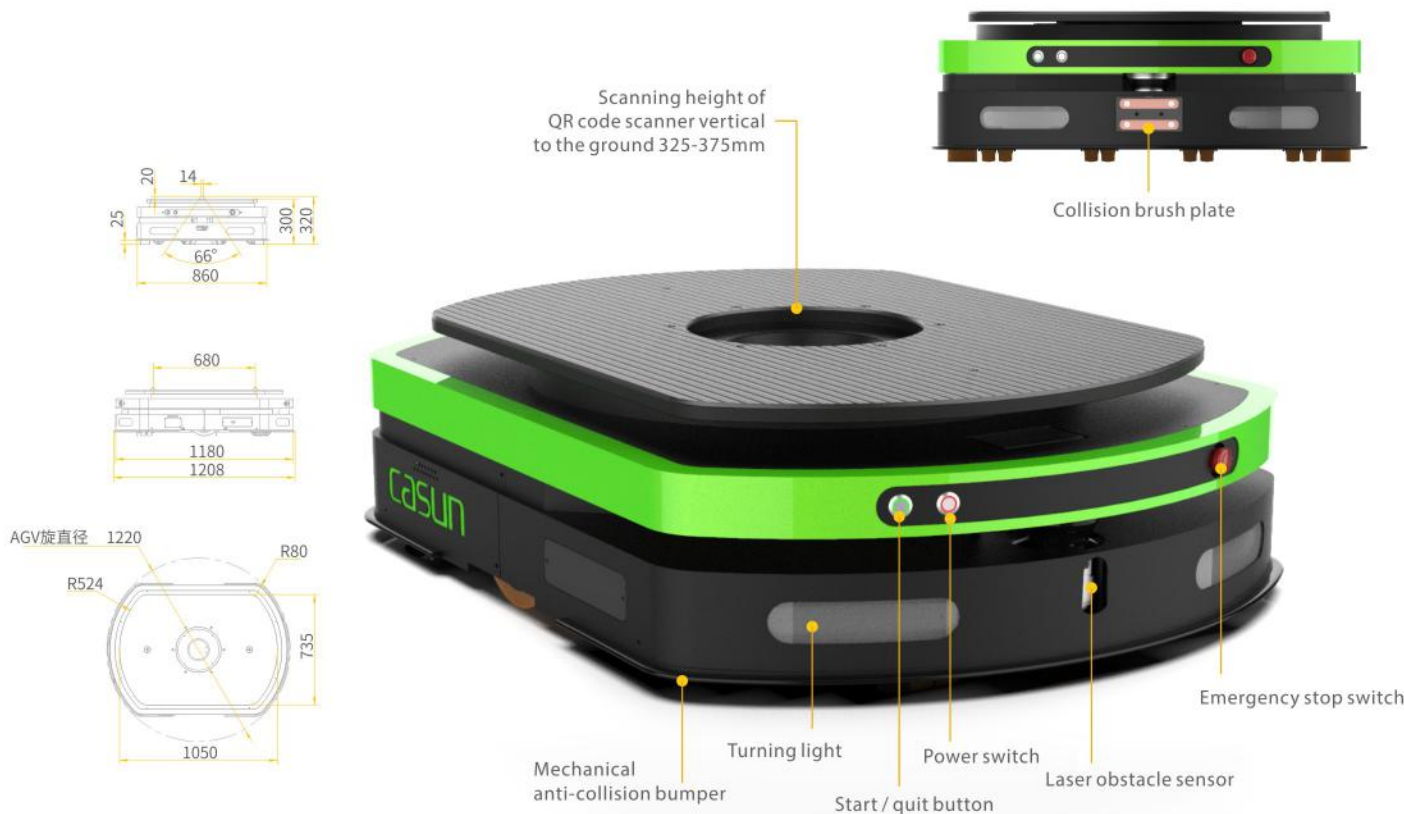

## Product advantages



The product performance is stable, and there are a large number of mature application cases;



The car body is flexible and the turning radius is small;



High delivery timeliness and high cost performance;



Flexible production to ensure smooth production lines;

## Application industries and scenarios



New energy photovoltaics, automobiles and parts, logistics and distribution, electronics and electrical, medical and other industries.



Production line materials, raw materials, parts transportation, goods-to-person selection, flexible production lines, etc.

## Project case - Cargo sorting project in a finished tobacco warehouse workshop

### Solution

This project is mainly used in the storage and sorting process of finished products in the tobacco industry. It mainly uses mobile robots to realize automatic handling and manipulator docking to realize automatic storage and sorting work; through the use of mobile robots, a certain tobacco logistics greatly reduces the number of personnel and labor intensity, and replaces manual labor for tedious and repetitive warehousing and warehousing actions.

In addition, the mobile robot is automatically docked with various process production equipment, which connects the production process links in series and realizes factory automation.

### Economic benefits



#### Improve efficiency

Flexible production line, the rate of on-site change is increased, and the incompatibility of the production line caused by changes in production orders is reduced.



#### Increase capacity

Seamlessly connect with WMS system, realize optimization of storage location, route, and task allocation, rationally plan warehouse layout, maximize use of space, and increase warehouse location by 20%.



#### Intelligent Scheduling

The storage information data of the warehouse location, inbound and outbound tasks, and on-site inbound and outbound equipment (mechanical arms, stacking machines, manual warehousing operation terminals, etc.) are managed by the customer's WMS system to monitor the status of factory materials in real time.



#### Cost saving

Reduce the number of operations by personnel, reduce the intensity of manual labor, reduce the rate of operational errors, improve the flexible process, and save a lot of labor costs.





# C2-26B

New energy lithium battery industry PACK line

## Product introduction

C2-26B two-way latent lifting mobile robot is suitable for workshops with relatively fixed production processes. The working method is: the mobile robot automatically lurks to the bottom of the material truck after receiving system instructions, and docks with the material vehicle through the lifting platform. Realize end-to-end transfer. A mobile production line can also be composed of multiple mobile robots to achieve flexible production in the factory. At present, the most widely used is the application scenario of the PACK line in the new energy lithium battery industry.

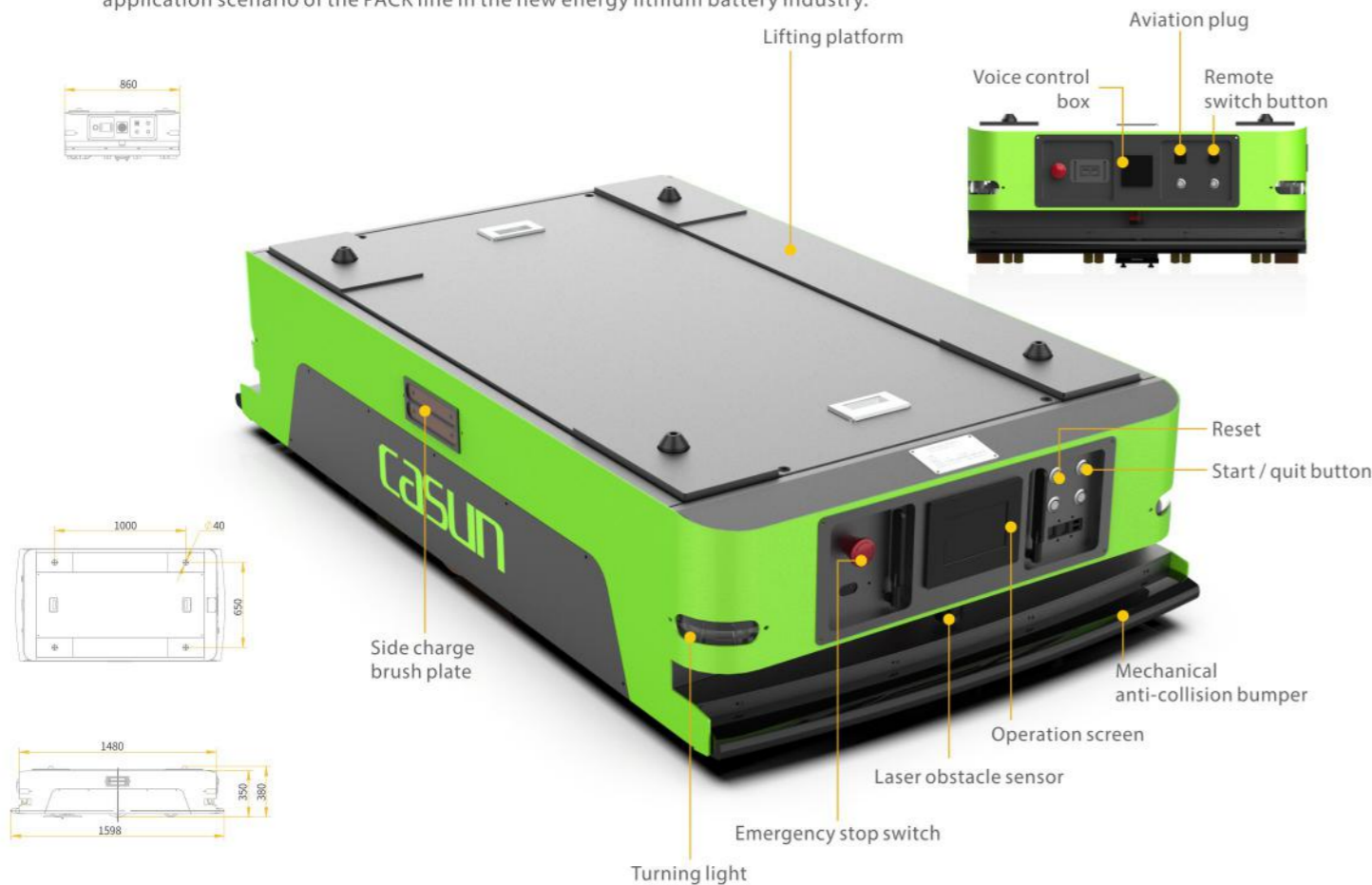

## Product advantages

The product performance is stable, and there are a large number of mature application cases;

Adapt to the lithium battery industry, tailor-made;

Flexible production to ensure smooth production lines;

## Application industries and scenarios

**application industry**  
Diversified industries such as new energy lithium batteries, automobiles, auto parts, and machinery manufacturing.

**application scenarios**  
End-to-end transportation of production line materials, raw materials and parts, forming a flexible production line, etc.

## Project case - Lithium battery PACK line project

The factory PACK line transfer project mainly realizes the material transfer between battery packs from assembly to testing to packaging, and its operation process is a circular assembly line. Through the CRMS mobile robot control system, autonomous ordering of materials, intelligent handling, information collection, and intelligent storage are realized, and it is seamlessly connected with the user's production management system.

Difficulties of the project: This project mainly solves the technical difficulties in the docking of various peripheral equipment systems, such as transmission equipment, robotic arms, etc.; secondly, it accurately realizes the priority logic judgment of the operation of the mobile robot, according to the sequence of different stations in order, the CRMS system automatically selects and determines the most suitable transportation route.

Solution

Economic benefits

**Reduce costs**  
Reduce the investment cost of fixed equipment: create a flexible production line and improve the flexibility of production scheduling.

**High reliability**  
Improve yield rate and accuracy rate: reduce material damage during handling, and reduce defect rate by 90%.

**Precise positioning**  
Improve the positioning accuracy of transportation: the transportation accuracy rate is increased to 99%, which can meet the peak demand of full production of the whole line.

**Intelligent logistics**  
Realize intelligent logistics in the field: realize the optimization of warehouse location, route and task allocation, and informatization of the whole process.





# C2-36

New energy lithium battery industry PACK line ▶

## Product introduction

C2-36 is a latent lifting AGV, equipped with omnidirectional drive, using QR code navigation, and the load can reach 1500KG. The model is compact and the lifting stroke is 60mm. Working method: After the AGV receives the system command, the AGV lurks to the bottom of the material rack, lifts the material rack, and carries out material transportation; it can also be composed of multiple AGVs to form a mobile production line to achieve flexible production. It has been widely used in new energy lithium batteries, automobile and parts industry, photovoltaic industry, 3C and semiconductor industry.

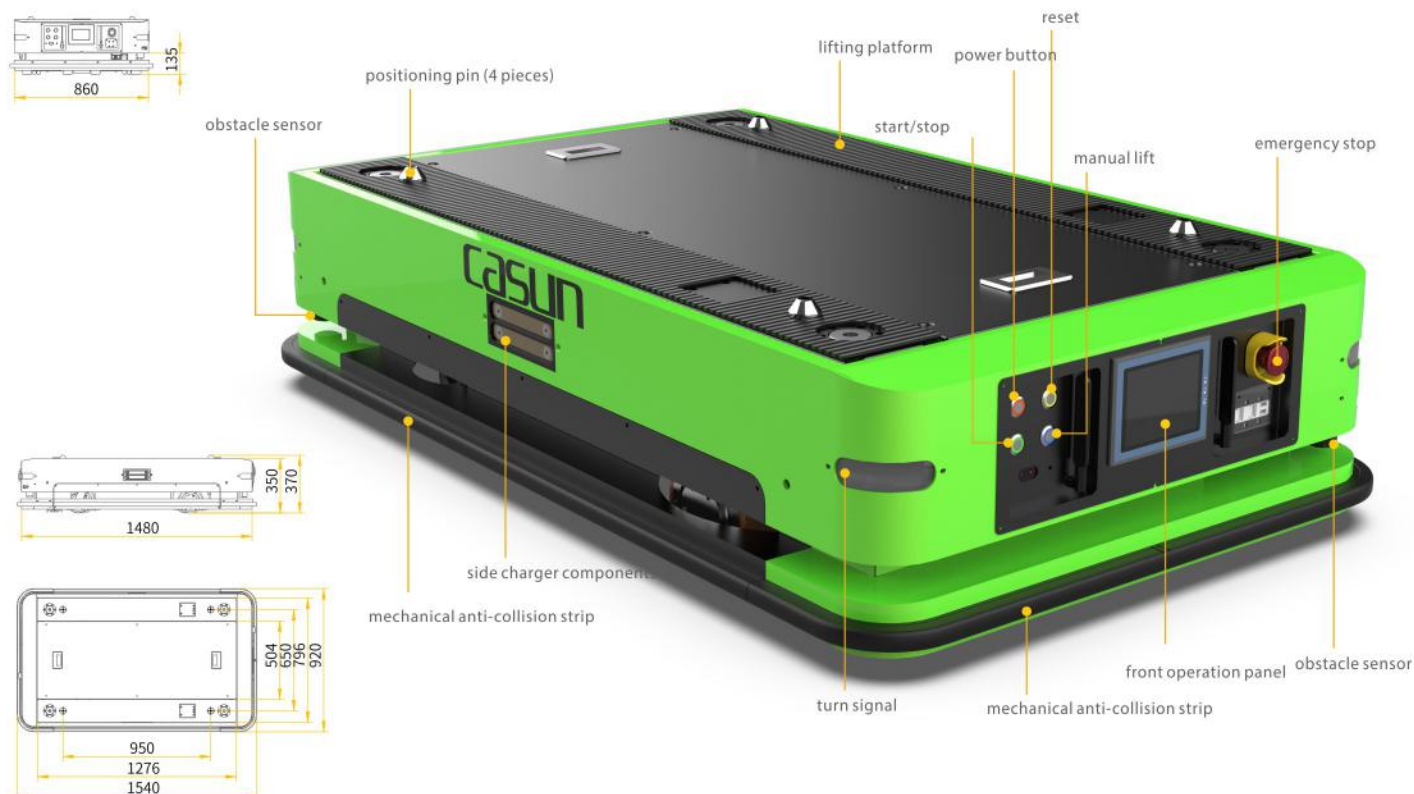

## Product advantages

 The product performance is stable, and there are a large number of mature application cases;

 Omni-directional operation, 360-degree safety protection;

 Flexible production, which can be adapted to battery packs of various specifications.

## Application industries and scenarios

 application industry  
New energy lithium batteries, automobiles, auto parts, machinery manufacturing and other diversified industries;

 application scenarios  
PACK line, raw materials of production line, end-to-end transportation of parts and components, forming a flexible production line, etc.

## Project case -Lithium battery PACK line project

**Solution**  
It mainly realizes the product transfer between battery packs from assembly to testing to packaging, and its operation process is a circular flexible production line. Through the system, autonomous ordering of materials, intelligent handling, information collection, and intelligent storage are realized, and it is seamlessly connected with the user's production management system.  
(2) Difficulties of the project: This project mainly solves the function of the AGV carrying the PACK material car to realize the lateral movement, reduces the space of the PACK material car running channel, and at the same time ensures that the orientation of the PACK material car is consistent with the site; secondly, it solves the problem Explain the technical difficulties of docking various peripheral equipment systems: such as MES docking of manual stations, test equipment, manipulators, safety grating docking of automatic stations, etc.

### Economic benefits

 **Cost reduction**  
Reduce the investment cost of fixed equipment: create a flexible production line and improve the flexibility of production scheduling.

 **High reliability**  
Improve the health rate and accuracy rate, reduce material damage during the handling process, and reduce the unhealthy rate by 90%

 **Precise positioning**  
Improve the positioning accuracy of transportation, and the transportation accuracy rate is increased to 99%, which meets the peak demand of full production of the whole line;

 **Intelligent logistics**  
Realize intelligent on-site logistics: Realize optimization of warehouse locations, routes, and task allocation, and informatization of the entire process.



CASUN



# C2-37

New Energy Lithium Industry PACK line test transfer



## Product introduction

performs precise positioning according to the scheduling task, and independently completes a series of operations of lifting, transporting and unloading. The navigation method is SLAM navigation, the load capacity is compatible with 1T, the lifting height is up to 248mm, and it can be applied to various height positions; it can detect low obstacles, and can perform two safety protections while lifting, which has a price competitive advantage.

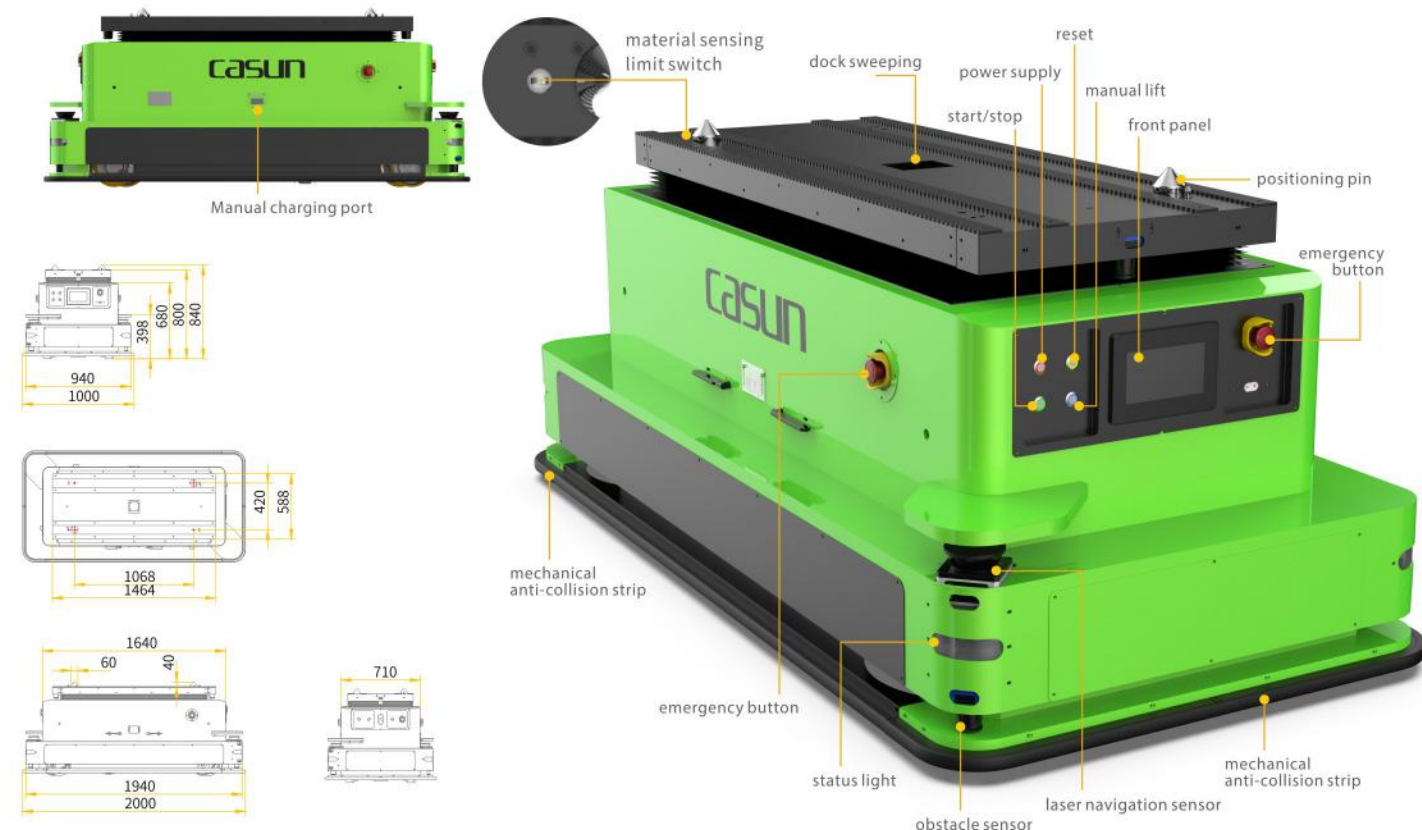

## Product advantages

The lifting stroke can reach 248mm, which can be applied to various heights of work stations.

Omni-directional operation, 360-degree safety protection.

Flexible production, which can be adapted to battery packs of various specifications.

## Application industries and scenarios

application industry  
New energy lithium batteries, automobiles, auto parts, machinery manufacturing and other diversified industries;

application scenarios  
PACK line, raw materials of production line, end-to-end transportation of parts and components, forming a flexible production line, etc.

## Project case - Lithium battery PACK line project

**Solution**  
It mainly realizes the material transferring between battery packs from assembly to testing to packaging, and its operation process is a circular assembly line. Through the CRMS mobile robot control system, the system realizes autonomous material calling, intelligent handling, information collection, and intelligent storage, and seamlessly connects with the user's production management system. The project uses AGV as a flexible distribution unit, which effectively solves the transportation problem compatible with hundreds of products of different models and specifications.

Difficulties of the project: This project mainly solves the function of the AGV carrying the PACK trolley to realize the lateral movement, reduces the space of the PACK material car running channel, and at the same time ensures that the orientation of the PACK trolley is consistent with the site; secondly, it solves the problem explained the technical difficulties of docking various peripheral equipment systems: such as MES docking of manual stations, test equipment, manipulators, safety grating docking of automatic stations, etc

### Economic benefits

TQCM  
Create a flexible production line and improve the flexibility of production scheduling

Reduce damage  
Improve yield rate and accuracy rate: reduce material damage during handling, and reduce defect rate by 90%

Intelligent logistics  
Realize the intelligentization of onsite logistics, realize the optimization of warehouse location, route and task allocation, and informatization of the whole process;

Digitalization & visualization  
Accurately collect data such as material efficiency, frequency, utilization rate, etc., and analyze them to improve the process and increase efficiency.



# C3

## — Load and transferring mobile robot



Series introduction



The mobile robot of the piggyback transfer series can autonomously navigate to the docking body according to the scheduling task, and realize the fully automatic transfer of materials. This series is divided into single station and multi-station according to the number of product stations. The navigation method can choose QR code navigation, laser positioning navigation, and SLAM navigation. This series of mobile robots are widely used, compact in structure, flexible in operation and high in automation.



Application environment

-10°C ~ 45°C; no dust, flammable, explosive and corrosive gases.



Model		C3-01	C3-04	C3-05
				
Basic Parameters	Dimension	L940*W680*H755 (mm)	L1550*W950*H2150 (mm)	L1550*W950*H1500 (mm)
	Max loading capacity	100kg	300kg	300kg
	Vehicle weight	300kg	350kg	300kg
	Rotation diameter	1250mm	1725mm	1725mm
	Docking height	820mm	the lower layer is 450mm the upper layer is 1300mm	the lower layer is 450mm the upper layer is 1000mm
	Material supporting size	700*450mm	/	/
	Docking direction	Forward,Backward	backward	backward
Navigation Performance	Material transfer mode	Roller	belt	belt
	Navigation mode	QR/SLAM	SLAM	SLAM
	navigation accuracy	±10mm / ±15mm	±10mm	±10mm
	Stop accuracy	±5mm / ±10mm	±5mm	±5mm
Movement Performance	Stop Angle accuracy	±1°	±1°	±1°
	Traveling direction	Forward,Backward,Rotate	Forward, backward, rotate	Forward, backward, rotate
	Drive mode	Two-wheel differential drive	Two-wheel differential drive	Two-wheel differential drive
	Acceleration	0.5m/s <sup>2</sup>	0.3m/s <sup>2</sup>	0.3m/s <sup>2</sup>
	Max running speed	1.5m/s	1.2m/s	1.2m/s
Battery Performance	Maximum climbing capacity	≤3°	≤3°	≤3°
	Battery type	Lithium battery	Lithium battery	Lithium battery
	Charging mode	Side charging	Side charging	Side charging
	Charging time	Charge time after full discharge: side charge ≤1H	Charge time after full discharge: side charge ≤1H	Charge time after full discharge: side charge ≤1H
Network	Rated endurance	4H	8H	8H
	Communciation mode	WiFi / 5G	WiFi / 5G	WiFi / 5G
Protective Performance	Safety warning	- Light warning - Voice broadcast	- Light warning - Voice broadcast	- Light warning - Voice broadcast
	Safe sensing range	≤3m adjustable	≤3m adjustable	≤3m adjustable
	Safety protection	- Front obstacle detection sensor - Mechanical anti-collision mechanism - Emergency stop switch	- Front and rear diagonal obstacle detection sensor 360° laser obstacle avoidance - Mechanical Anti-collision Structure; - Emergency Stop Switch	- Front and rear diagonal obstacle detection sensor 360° laser obstacle avoidance - Mechanical Anti-collision Structure; - Emergency Stop Switch

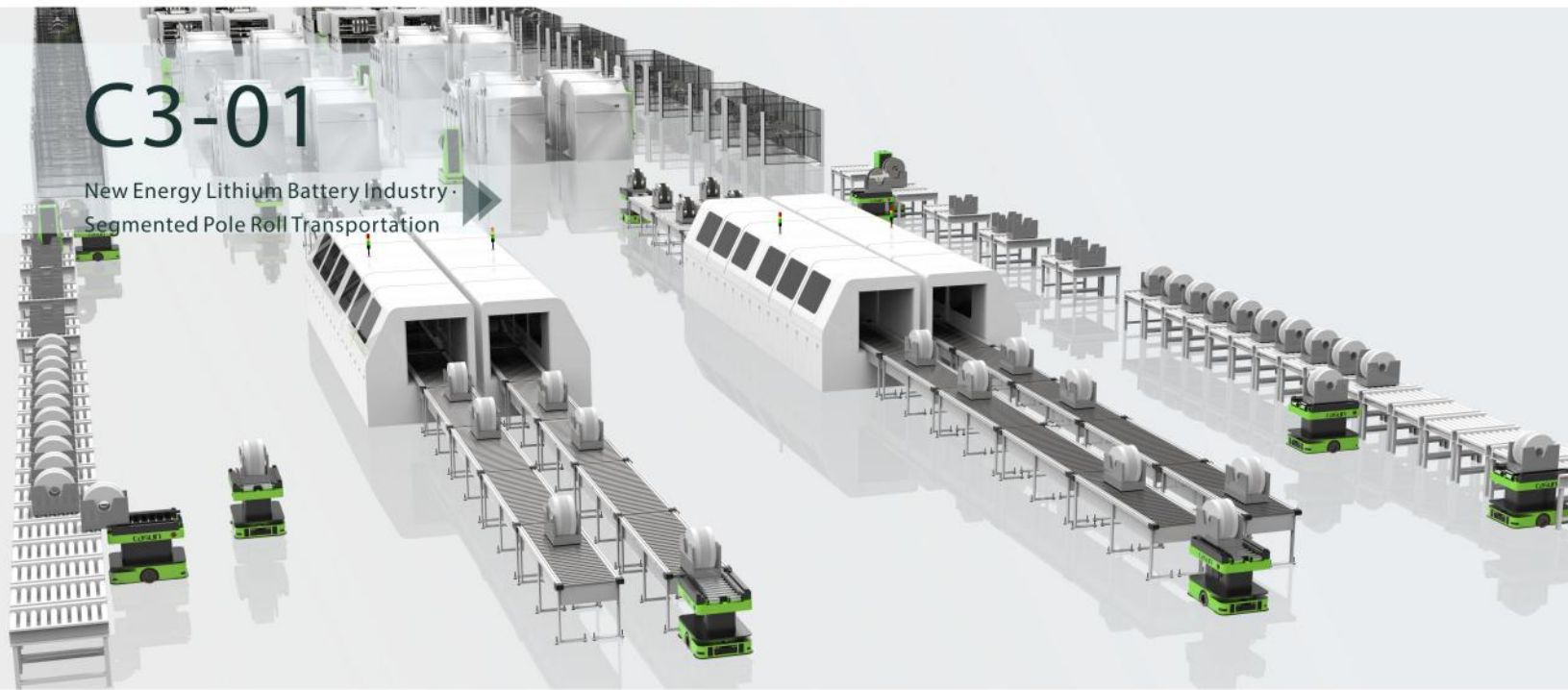

### Product introduction

C3-01 is a roller-carrying mobile robot, which can use QR code navigation, laser positioning navigation, and SLAM navigation technology. Load capacity is 100kg. Double-layer workstations can realize fast interaction between empty and full materials. It can be widely used in new energy lithium battery, new energy photovoltaic, injection molding industry, 3C and semiconductor, flat panel display and other industries.

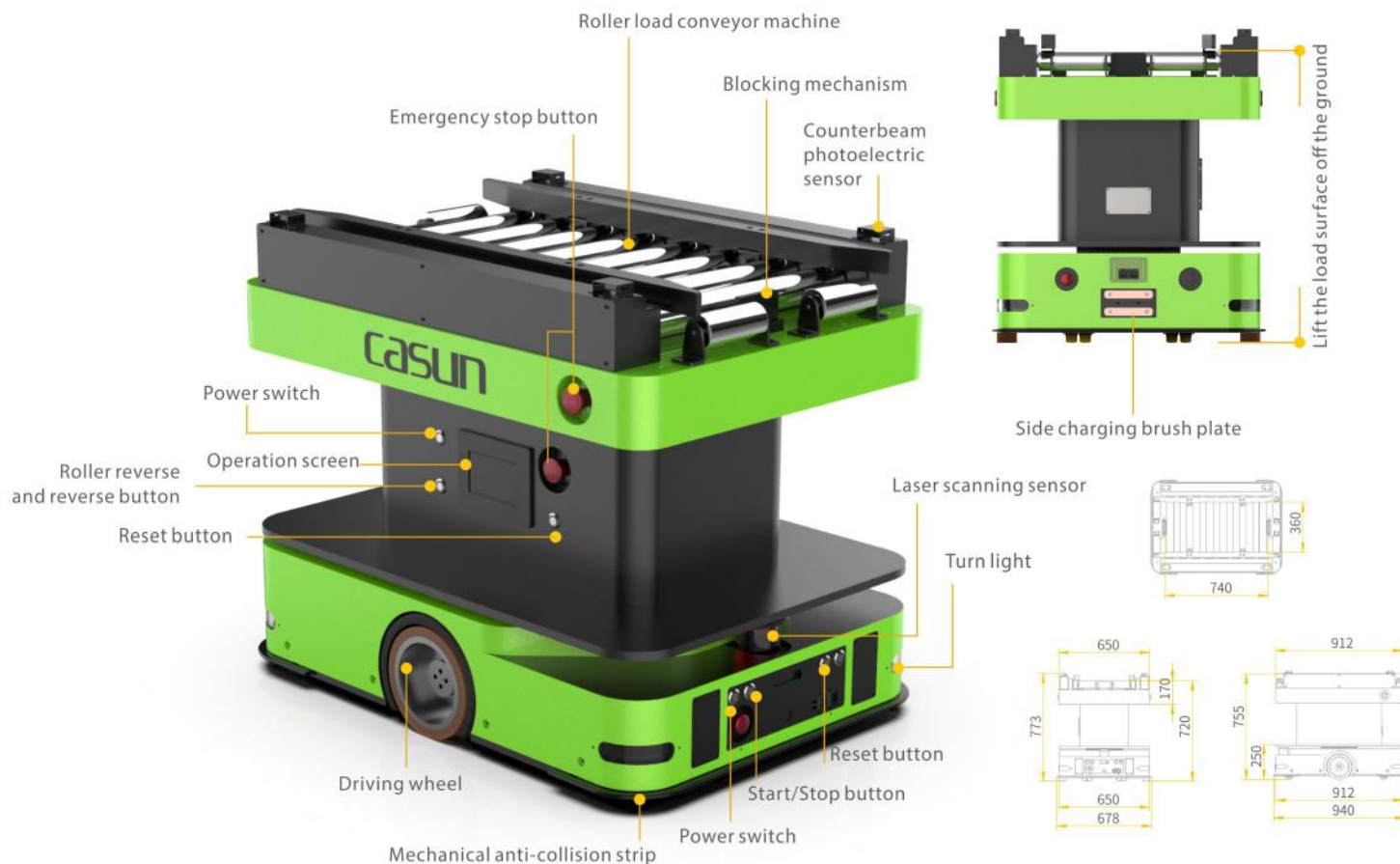

### Product advantages

- Adopt the most advanced SLAM navigation technology;
- It adopts double-layer drum design, matching with the double-layer drum line of the injection molding machine, and automatically completes the empty and full exchange;
- The car body is flexible and the turning radius is small; it cooperates with the injection molding machine to realize the unmanned operation of the process;

### Application industries and scenarios

- application industry**  
New energy lithium battery, injection molding industry, 3C and semiconductor, LCD panel and other industries.
- application scenarios**  
The process scene where the material of the material box type is docked by the roller

### Project case - 3C injection molding workshop project

19 injection molding machines transfer the injection molded parts between 4 assembly machines; through the CRMS mobile robot control system, autonomous ordering, intelligent handling, information collection, and intelligent storage are realized, and there is no connection with the user's production management system. Seam docking, unmanned operation throughout the process.

Difficulties of the project: This project mainly solves the technical difficulties in the docking of various peripheral equipment systems, such as transmission equipment, robotic arms, etc.; secondly, it accurately realizes the priority logic judgment of the operation of the mobile robot, according to the sequence of different stations. In order, the CRMS system automatically selects and determines the most suitable transportation route.

#### Solution

- Realize unmanned**  
Build a black lamp factory, dock with injection molding machine robots and conveyor lines, and realize unmanned chemical factories.
- Data interaction and sharing**  
Interaction with Party A's equipment and systems: CRMS system can be seamlessly connected with on-site automation equipment systems and customer systems to realize data transmission.
- Intelligent logistics**  
Warehouse location storage information data, inbound and outbound tasks, and onsite inbound and outbound equipment (mechanical arms, stacking machines, manual warehousing operation terminals, etc.) are managed by the customer's WMS system to monitor the status of factory materials in real time.



CASUN

# C3-04

The basket automatic loading and unloading



## Product introduction

C3-04, mainly used in photovoltaic industry cell production workshop, the basket automatic loading and unloading. The navigation mode is SLAM navigation, the load capacity is 300kg, and the maximum speed is 1.2m/s. The working mode is that after receiving the system instruction, the AGV can automatically dock and transport the basket. The AGV basket structure designing has reserved the configuration space of wet basket operation, and can be designed and developed according to the technical requirements of wet basket (acid, alkali and pollution prevention).

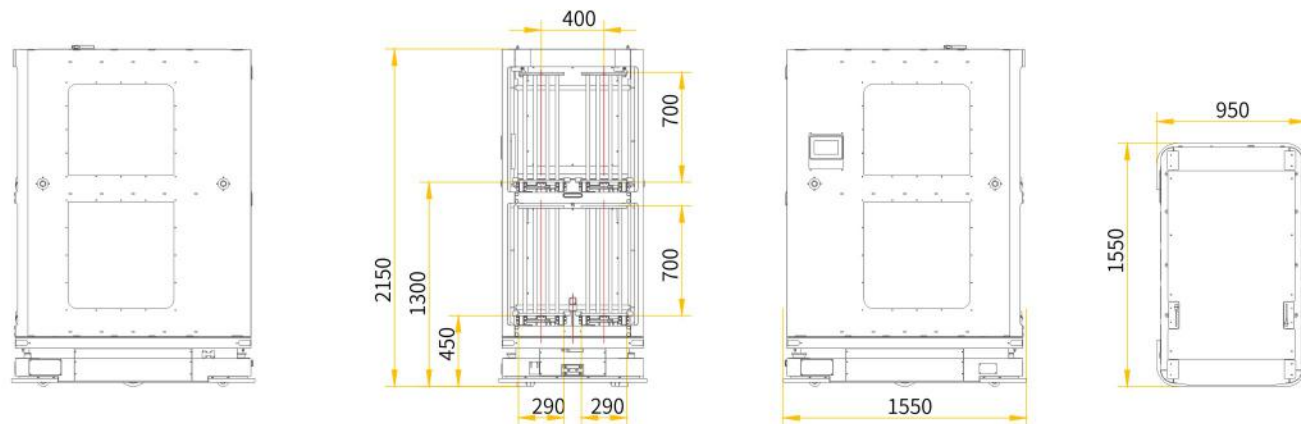

## Product advantages

Using advanced SLAM+ visual navigation technology;

Double-layer and double-track transmission, which can improve production efficiency;

Adopt type structure, 360° obstacle avoidance, and ensure production safety

## Application industries and scenarios

application industry  
Photovoltaic industry, 3C and semiconductor, LCD panel and other industries.

application scenarios  
Process scenario of automatic loading and unloading and box type materials docking through the conveyor line

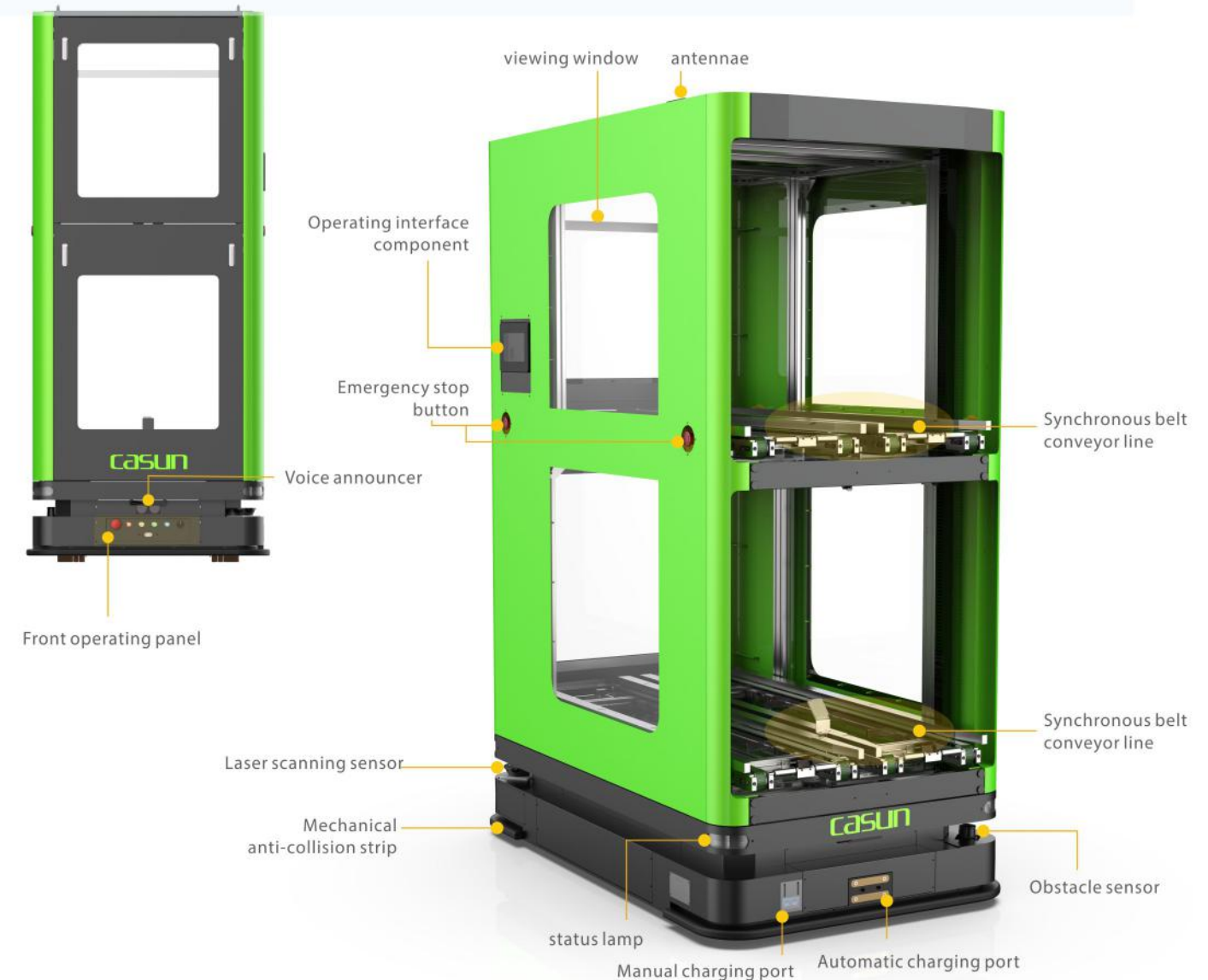

# C3-05

BIN box automatic loading and unloading



## Product introduction

C3-05, is mainly used for photovoltaic industry cell production workshop, BIN box automatic loading and unloading. The navigation mode is SLAM+ visual navigation, the loading capacity is 300kg, and the maximum speed is 1.2m/s. After receiving the system instruction, the AGV automatically interconnects and transports the BIN box.

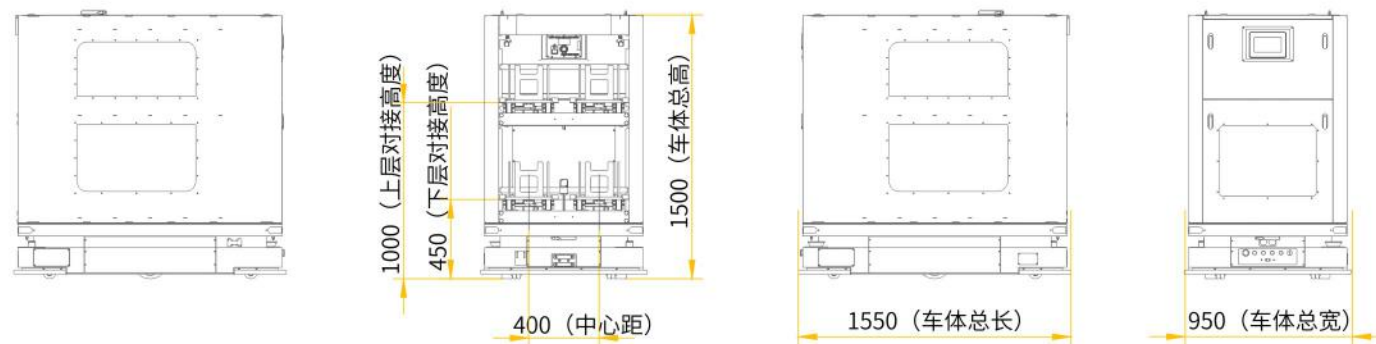

## Product advantages

Using advanced SLAM+ visual navigation technology;

Double-layer and double-track transmission, which improve production efficiency;

Adopt type structure, 360° obstacle avoidance, and ensure production safety

## Application industries and scenarios

application industry  
Photovoltaic industry, 3C and semiconductor, LCD panel and other industries.

application scenarios  
BIN box automatic loading and unloading process scenarios. Bin type Materials are docking through transport cables



# C5 – Intelligent forklift mobile robot

## Series introduction

Intelligent forklift series mobile robots are divided into handling type and stacking type. The navigation method of the intelligent forklift series adopts laser positioning and navigation. This series of products has a high degree of intelligence and is widely used in many industries such as new energy lithium batteries, auto mobiles and parts, flat panel displays, food and beverage, 3C and semiconductors, household appliances, home textiles, etc. And new scenarios such as warehouse entry and exit, loading and unloading, and material transfer in logistics and circulation.

## Application environment

-10°C ~ 45°C; no dust, flammable, explosive and corrosive gases.

Model C5-B2 Handling Type C5-B6 Handling Type C5-D1 Stacking Type

Model	C5-B2 Handling Type	C5-B6 Handling Type	C5-D1 Stacking Type	
				
Basic parameter	Dimension	L1585*W780*H2035 (mm)	L1120*W600*H788 (mm)	L1653*W856*H2295 (mm)
	Fork size	1170*188*55 (mm)	/	1150*188*55 (mm)
	Fork outside distance	570/680mm	/	570 / 680mm
	Max load capacity	1000kg	500kg	1000kg
	Truck weight (battery included)	400kg	392kg	600kg
	Turning radius	1350mm	1500mm	1350mm
	Lifting height	120mm	120mm	1600mm
Applicable carrier	Pallet type	Two-way Entry	/	Two-way Entry
	Pallet size	1200*1000mm / 1100*1100mm	/	1200*1000mm / 1100*1100mm
Navigation performance	Navigate mode	Laser	Laser	Laser
	Navigation accuracy	±10mm	±10mm	±10mm
	Stop accuracy	±10mm	±10mm	±10mm
Movement performance	Travelling direction	Forward,Backward,Rotate	Forward,Backward,Rotate	Forward,Backward,Rotate
	Drive mode	Single Steering Wheel Drive	Two-wheel differential drive	Single Steering Wheel Drive
	Acceleration	0.35 m/s <sup>2</sup>	0.5m/s <sup>2</sup>	0.35 m/s <sup>2</sup>
	Single wheel drive	1.2 m/s	1m/s	1.2 m/s
	Maximum climbing capacity	3° / 2°	≤3°	≤3°
Battery performance	Battery type	Lithium Battery	Lithium Battery	Lithium Battery
	Charging mode	Side Charging	Side Charging	Side Charging
	Charging time	≤1H After Full Discharge	1H	≤1H After Full Discharge
	Rated endurance	6H	8H	6H
Network	Communciation mode	WiFi / 5G	WiFi / 5G	WiFi / 5G
Protective performance	Safety warning	Light Warning;Voice Broadcast	Light Warning;Voice Broadcast	Light Warning;Voice Broadcast
	Safe sensing range	Adjustable when ≤3m	Adjustable when ≤3m	Adjustable when ≤3m
	Safety protection	-Front/Rear Obstacle Detection Sensors -Mechanical Anti-collision Structure -Emergency Stop Switch	-Front/Rear Obstacle Detection Sensors -Mechanical Anti-collision Structure -Emergency Stop Switch	-Front/Rear Obstacle Detection Sensors -Mechanical Anti-collision Structure -Emergency Stop Switch
	Fork protection	Mechanical Collision+Photoelectric Sensors	Mechanical Collision+Photoelectric Sensors	Mechanical Collision+Photoelectric Sensors

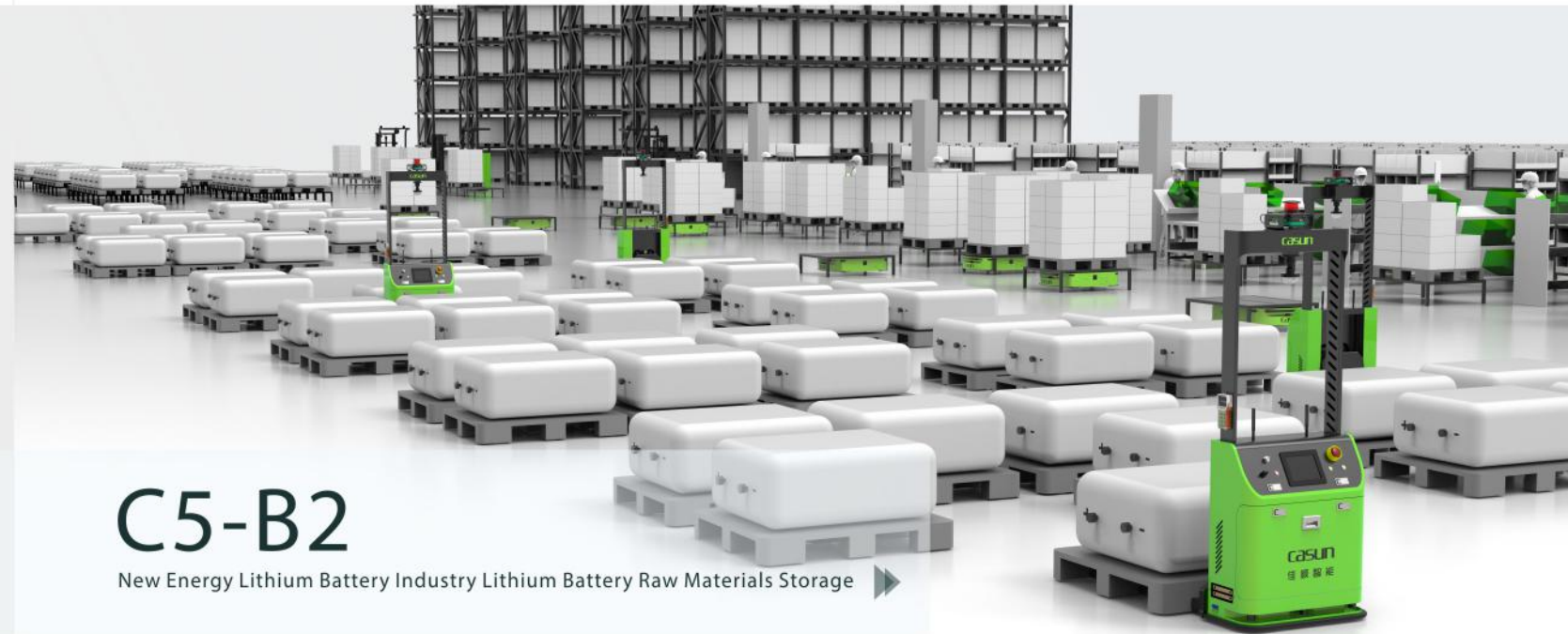

# C5-B2

New Energy Lithium Battery Industry Lithium Battery Raw Materials Storage

## Product introduction

suitable for workshops with limited factory area and multiple production processes. The working method is that the AGV automatically picks up the bottom of the pallet after receiving the system command, and realizes end-to-end transfer by lifting and connecting the pallet. This model adopts laser navigation and positioning, and has been widely used in automobiles and parts, new energy lithium batteries, food and beverage, household appliances and other industries.

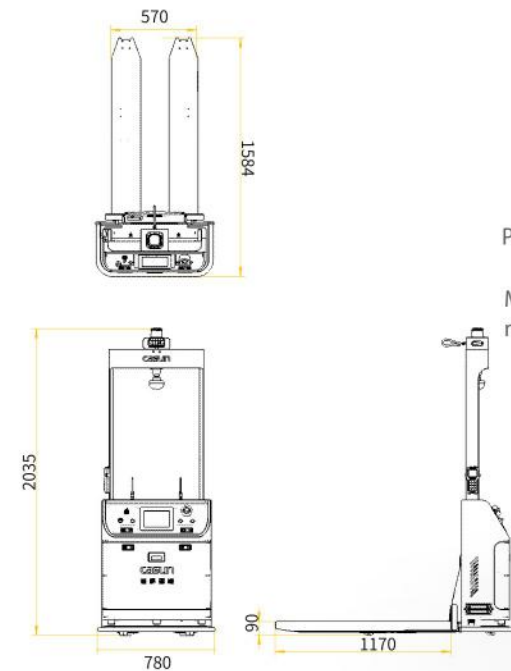

## Product advantages

The car body is small and exquisite, and can be carried in narrow passages;

When the turning radius is limited, it can turn 90 degrees and turn around 180 degrees in situ;

The minimum right-angle stacking channel width is 2m

## Application industries and scenarios

**application industry**  
Diversified industries such as new energy lithium batteries, automobiles and parts, machinery manufacturing, electronics, electrical appliances, and new energy.

**application scenarios**  
Production line raw materials, parts transportation, etc.

## Project case - Automobile air pipe production workshop and finished product warehousing project

Solution

Project features: Break through the barriers of information transmission, by connecting to the customer's ERP system, reading the feedback information of the line scanning code, according to the type of material, the intelligent dispatching robot will send the goods to the inspection station and dock with the outdoor mobile robot, seamless relay. Or send it to the GP12 waiting area for manual sorting, and integrate the indoor and outdoor material transportation into one, realizing the unmanned transportation of materials across the factory from the production line to the outdoor warehouse.

Project features: Break through the barriers of information transmission, by connecting to the customer's ERP system, reading the feedback information of the line scanning code, according to the type of material, the intelligent dispatching robot will send the goods to the inspection station and dock with the outdoor mobile robot, seamless relay. Or send it to the GP12 waiting area for manual sorting, and integrate the indoor and outdoor material transportation into one, realizing the unmanned transportation of materials across the factory from the production line to the outdoor warehouse.

Economic benefits

**Improve efficiency**  
Improve the efficiency and accuracy of lineside transportation, so that materials can be accurately delivered to the corresponding buffer area.

**High reliability**  
Improve the yield rate and accuracy rate: reduce material damage during handling, and increase the accuracy rate to 99%

**Cross-factory transportation**  
The efficiency of crossfactory transshipment is improved, and the indoor arrival information can be transmitted to the outdoor mobile robot for connection at the first time, without waiting time wasted.





**C5-B6**  
Automobile and parts industry-Material transfer

### Product introduction

C5-B6 carries out precise positioning according to dispatching tasks, and independently completes a series of operations of lifting, transportation, and unloading. The navigation method is SLAM navigation + two-dimensional code assisted positioning, with a load capacity of 500Kg and a lifting stroke of 120mm. Available in new energy lithium batteries, automobiles and parts, flat panel display, food and beverage, 3C and semiconductor industries.

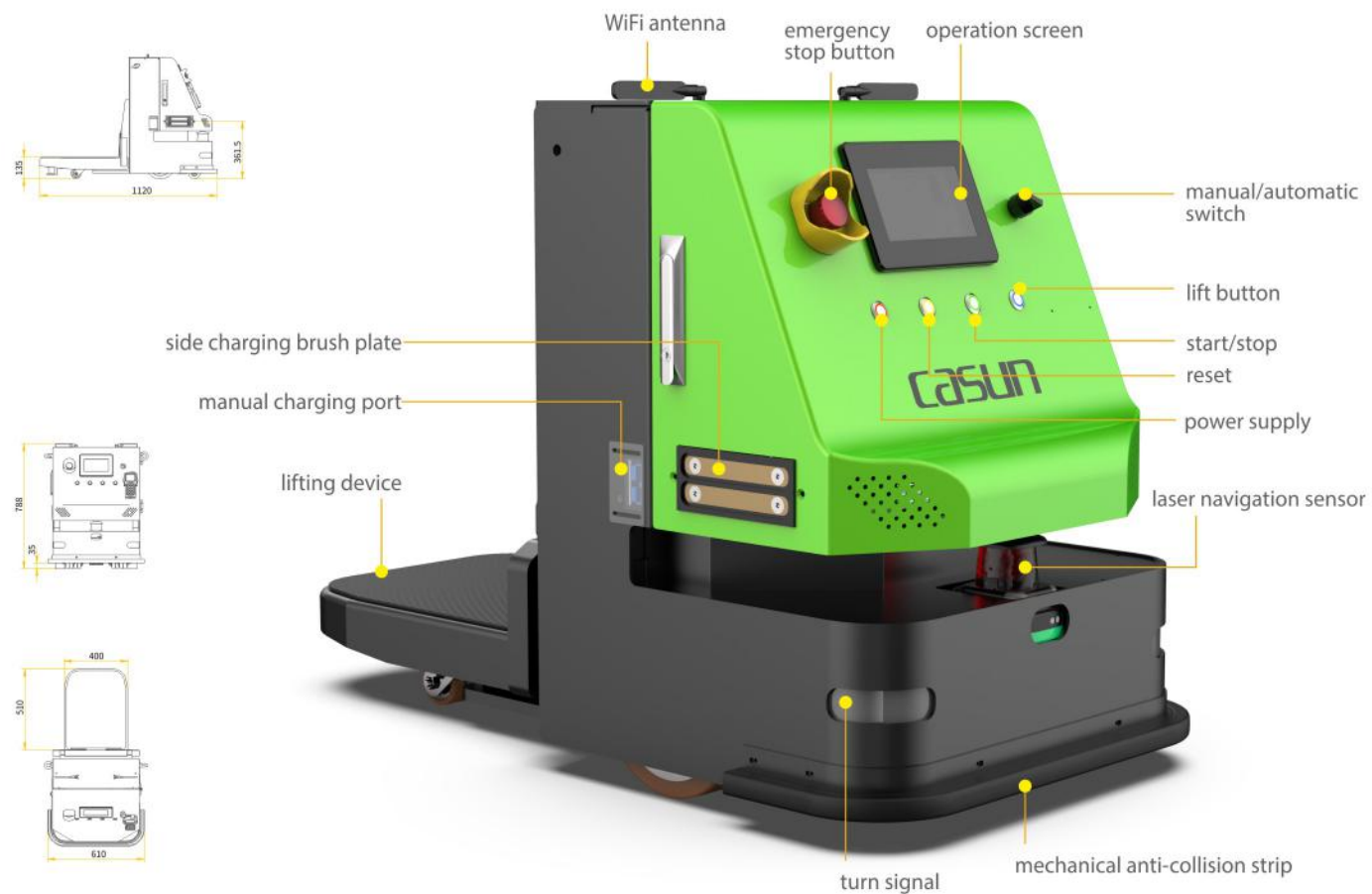

### Product advantages

 The car body is flexible and can rotate 360°

 The appearance is compact and can be applied in scenarios with small logistics channels

 High delivery time and high cost performance

### Application industries and scenarios

 application industry  
Auto parts industry, 3C and semiconductor industry

 application scenarios  
Applicable to the handling scene of small trucks

### Project case - Auto parts project

**Solution** This project uses C5-B6 intelligent forklift trucks to realize the distribution of raw materials from the warehouse of raw materials to the manual station of the production line, and the material distribution of small racks. Area, to meet the on-site narrow roadway transportation; realize the scene operation of material transportation. Realize intelligent planning of the optimal path: Relying on the AI algorithm, the AGV can independently judge the priority of the transportation task and formulate the optimal path.

### Economic benefits

 **TQCM**  
Cost reduction and efficiency increase replace manual handling and logistics distribution, reduce labor input and improve production efficiency;

 **Scene optimization**  
It can realize the problem of small rack handling, and it can realize rack handling in the environment with small space area;

 **Accurate positioning**  
Improve the positioning accuracy of transportation: the transportation accuracy rate is increased to 99%, which meets the peak demand of full production of the whole line;

 **Intelligent logistics**  
Realize the intelligentization of logistics in the factory: realize the interaction of multisystem docking information and the informatization of the whole process.





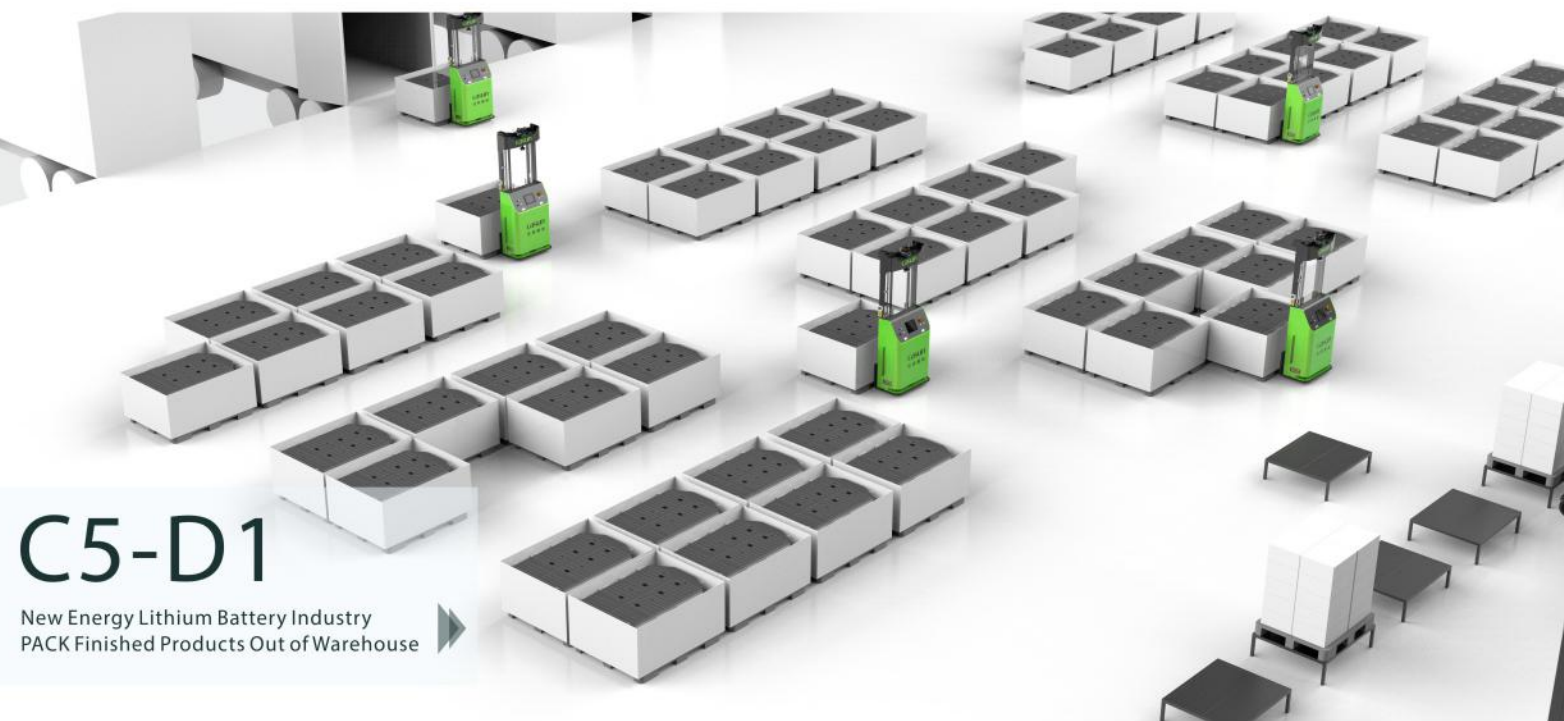

# C5-D1

New Energy Lithium Battery Industry  
PACK Finished Products Out of Warehouse

## Product introduction

C5-D1 mini stacking laser forklift has a load capacity of 1000KG, a running speed of up to 1.2m/s, and a lifting height of 1.6m; the extreme dimensions L1653\*W856\*H2295mm make it capable of The ability to operate in extremely narrow lanes requires a minimum width of 900mm for logistics channels (1200mm for ordinary forklifts), which greatly improves space utilization. At present, it has been widely used in diversified enterprises such as new energy lithium batteries, logistics and circulation, 3C and semiconductors, food and beverage, and traditional manufacturing.

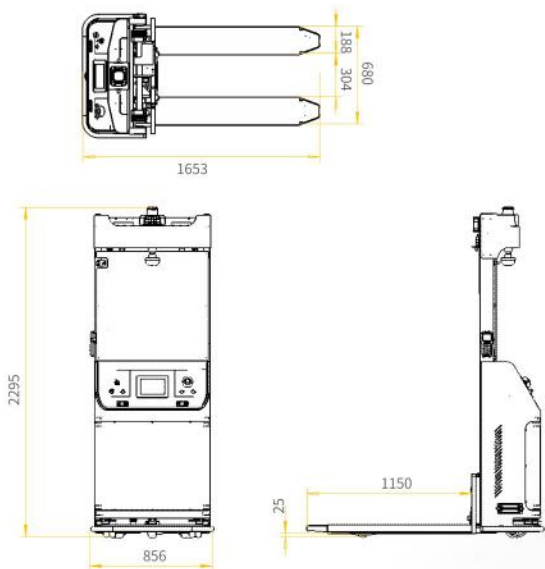

## Product advantages

**Stable product performance and high navigation accuracy;**

**The body design is compact, and the turning radius is only 1350mm, which is suitable for logistics handling in narrow lanes of various industries;**

**Flexible production to ensure smooth production lines;**

**Flexible production to ensure smooth production lines;**

## Application industries and scenarios

**New energy lithium battery, 3C electronics, food, military industry, traditional manufacturing and other diversified enterprises.**

**Production line pallet material raw materials, parts end - storage ground/low shelf - multi-specification Chuan-shaped pallet handling on the side of the production line.**

## Project case - A lithium battery module product inbound and outbound transportation project

This project uses a C5-D1 intelligent forklift to automatically transport battery module products into and out of the warehouse. It can lift up to 1.6m and meet the on-site narrow roadway transportation.

Solution

Economic benefits

**Reduce costs**  
reduce equipment and manpower input costs;

**High reliability**  
improve the timeliness of material transportation, and the transportation accuracy rate is increased to 99%, which can meet the peak demand of full production of the whole line;

**High safety**  
improves the safety of product transportation and ensures the product yield;

**Logistics intelligence**  
realizes the intelligentization and automation of the entire production process, monitoring and tracking of the whole process from product offline - storage - delivery, production data statistics, and report generation.



Case

## — Mobile robot for new energy

# CCM

### Series introduction

The CCM series is a mobile robot customized for the industry. It is a new model customized and developed according to the actual needs of the new energy lithium battery project, with flexible applications. At present, special-purpose robots for new energy include: double-fork lifting mobile robots, single-fork lifting mobile robots and single-cantilever mobile robots, which are mainly used to complete the handling and loading and unloading of pole coils, which can meet the high-precision docking of the lithium battery industry. MES system docking, multiple safety protection, production requirements for strict environmental cleanliness.

Application environment -10°C ~ 45°C; no dust, flammable, explosive and corrosive gases.

### 产品型号

### CCM-51 Double fork lifting AGV

### CCM-52 Single fork lifting AGV

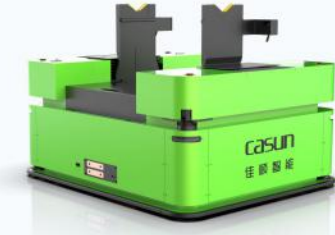

		CCM-51 Double fork lifting AGV	CCM-52 Single fork lifting AGV
Basic Parameters	Dimensions	L1800*W1800*H1800(mm)	L1800*W1500*H1200mm
	Maximum Load	1800kg	1800kg
	Rotation Diameter	2435mm	2220mm
	Docking Height	1800±50mm	1300~1800mm
Navigation Performance	Navigation Method	Laser Slam/QR code	Laser Slam/QR code
	Navigation Accuracy	±10mm	±10mm
	Stop Accuracy	±5mm	±3mm
	Docking Accuracy	±1mm	±2mm
Athletic Performance	Moving Direction	Forward,Backward,Turn,Rotate,Transverse Moving	Forward,Backward,Turn,Rotate,Transverse Moving
	Drive Mode	teering Wheel Drive	teering Wheel Drive
	Maximum Moving Speed	1.0 m/s	1.0 m/s
Battery Performance	Battery Type	Lithium Battery	Lithium Battery
	Charging Method	Side Charging	Side Charging
	Charging Time	≤1.5H After Full Discharge	≤1H After Full Discharge
	Rated Endurance	6H	6H
Network Performance	Communication Method	WiFi / 5G	WiFi / 5G
Protection Performance	Safety Alert	Light Warning;Voice Broadcast	Light Warning;Voice Broadcast
	Safety Sensing Range	Adjustable when ≤3m	Adjustable when ≤3m
	Security	5 Obstacle Detection Sensors; Mechanical Anti-collision Structure; Emergency Stop Switch	4 Obstacle Detection Sensors; Mechanical Anti-collision Structure; Emergency Stop Switch



# CCM-51

New Energy Lithium Battery Industry  
Coil material transport in cell workshop

## Product introduction

CCM-51 is a double-fork lifting AGV. Its working mode is: one pair of forks are placed with a full roll of material, and the other pair of forks are placed with an empty reel. The two states are operated alternately at the same interface to realize automatic loading and unloading of materials.

At present, the most widely used in the new energy lithium industry cell production workshop of the front section of the process, for foil and uncut pole roll handling.

## Material Specification

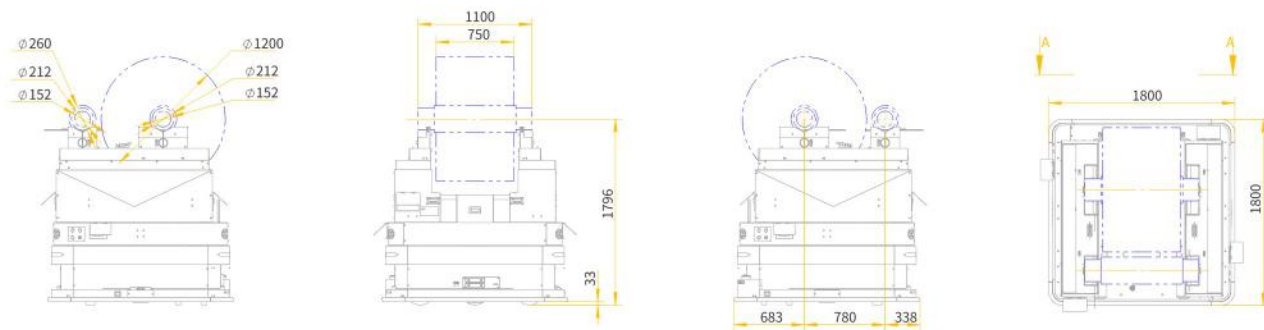

Drum	Drum inner diameter	Drum outer diameter	Drum length	Drum diameter	Weight
Empty drum	152mm	212mm	1100mm	/	/
Full drum	152mm	212mm	1100mm	≤1200mm	≤1800KG

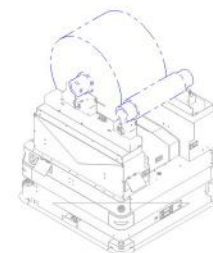

## Product advantages

**A**  
The navigation mode is optional: SLAM navigation or QR code navigation;

**↔**  
Automatic docking with the line equipment to realize the process of unmanned operation;

**⚙️**  
Double fork design is adopted to complete the empty and full exchange, improve work efficiency and reduce the waiting time of equipment downtime;

**📏**  
High precision control, the docking accuracy with the equipment is ±1mm.

## Application industries and scenarios

New energy lithium industry; Coil material transport in cell workshop

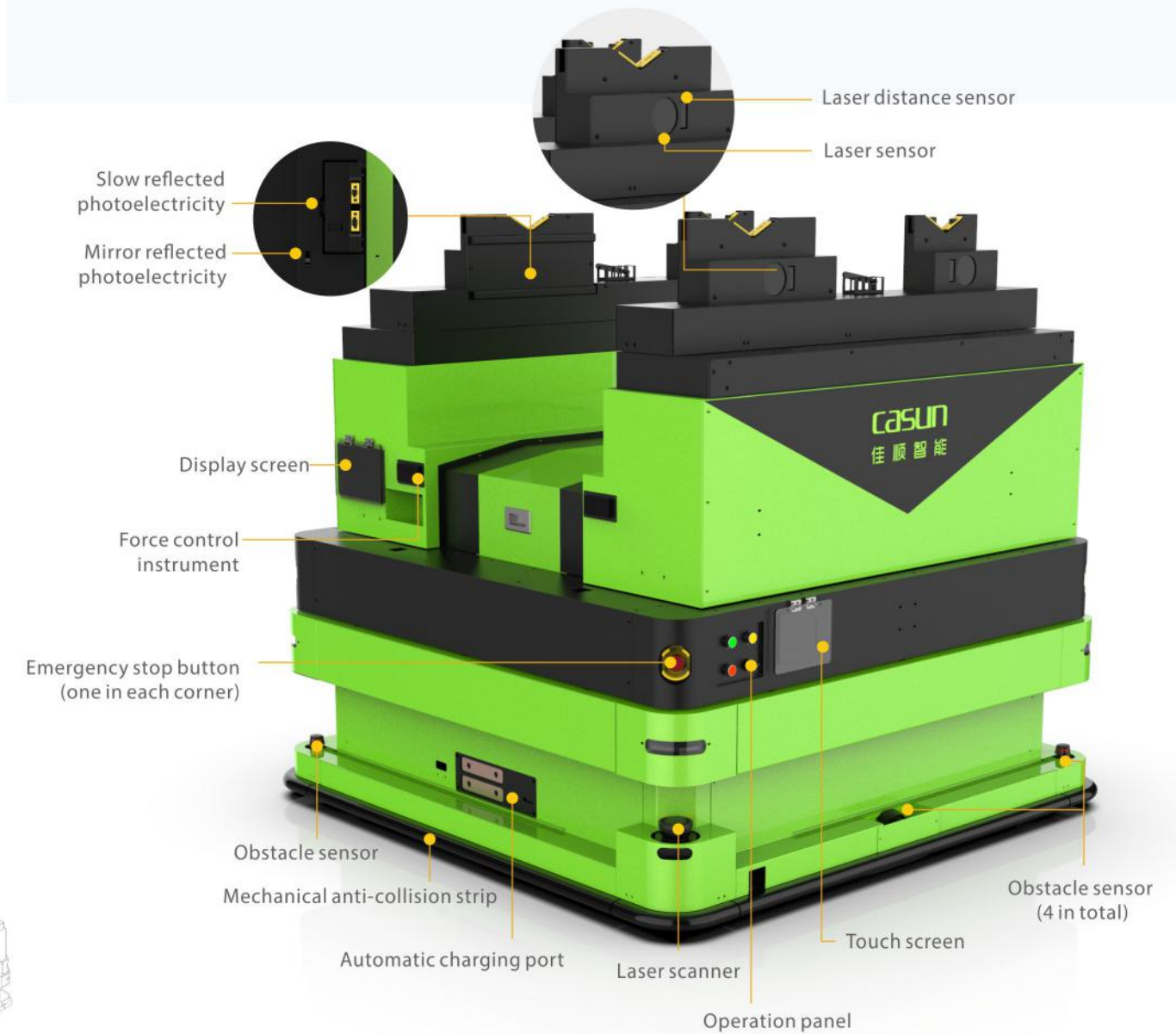



**Product introduction**

CCM-52 is a single-fork lifting AGV. Its working mode is as follows: the AGV carries a full roll of material or an empty reel for automatic docking with the connection port to realize automatic loading and unloading of materials.

At present, the most widely used in the new energy lithium industry cell production workshop of the front section of the process, for foil and uncut pole roll handling.

**Material Specification**



Drum	Drum inner diameter	Drum outer diameter	Drum length	Drum diameter	Weight
Suitable coiling	152mm	200mm	1100mm	≤1200mm	≤1800KG

**Product advantages**

The navigation mode is optional: SLAM navigation or QR code navigation;

Automatic docking with the line equipment to realize the process of unmanned operation;

High precision control, the docking accuracy with the equipment is ±2mm.

**Application industries and scenarios**

New energy lithium industry; Coil material transport in cell workshop

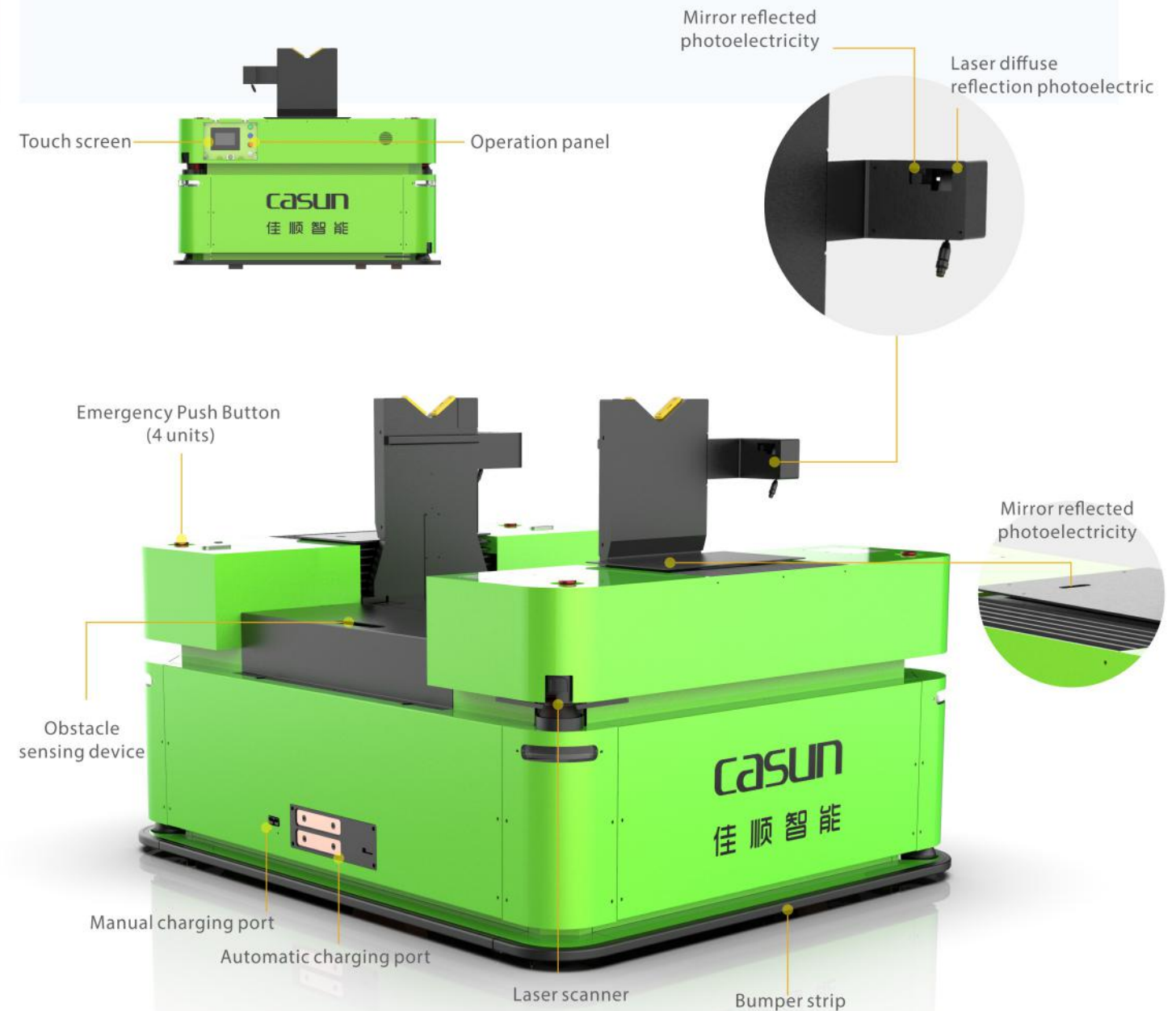

# CCS Charging Station Series

## 系列介绍

CCS charging station series, composed of charger, control unit, display unit, telescopic electrode, etc., with voltage and current over voltage overload protection mechanism, charging speed, high safety performance. This series is divided into: side charge, ground charge, impact charge, wireless charge,



Charging mode side charge

Model	CCS-11
Dimension	L600xW380xH1000(mm)

Voltage	Power
24V	1500W—5000W
48V	1500W—5000W



Charging mode ground charge

Model	CCS-21
Dimension	L600xW380xH1000(mm)

Voltage	Power
24V	1500W—5000W
48V	1500W—5000W



Charging mode side charge

Model	CCS-12
Dimension	L669*W488*H1018 (mm)

Voltage	Power
24V	4000W—6000W
48V	2500W—6000W



Charging mode impact charge

Model	CCS-31
Dimension	L490*W385*H355 (mm)

Voltage	Power
24V	1500W—5000W
48V	1500W—5000W



# CASUN Mobile Robot Control System

## System Introduction

The mobile robot control system mainly deals with the task assignment, path planning, traffic control and state monitoring of robot cluster, and completes data collection through the sensing module carried by mobile robot, so as to analyze and make decisions on production efficiency. At the same time, it provides open standard API, which is easy for customers' business systems to develop and call, and provides a solid guarantee for customers to introduce large-scale mobile robots in intelligent warehousing and intelligent factory scenarios.

## System Feature

support the coexistence of combined traffic control with other AGV manufacturers and multiple navigation modes

Provide standard interface for customized development and support docking with elevators, elevators and other customer automation equipment

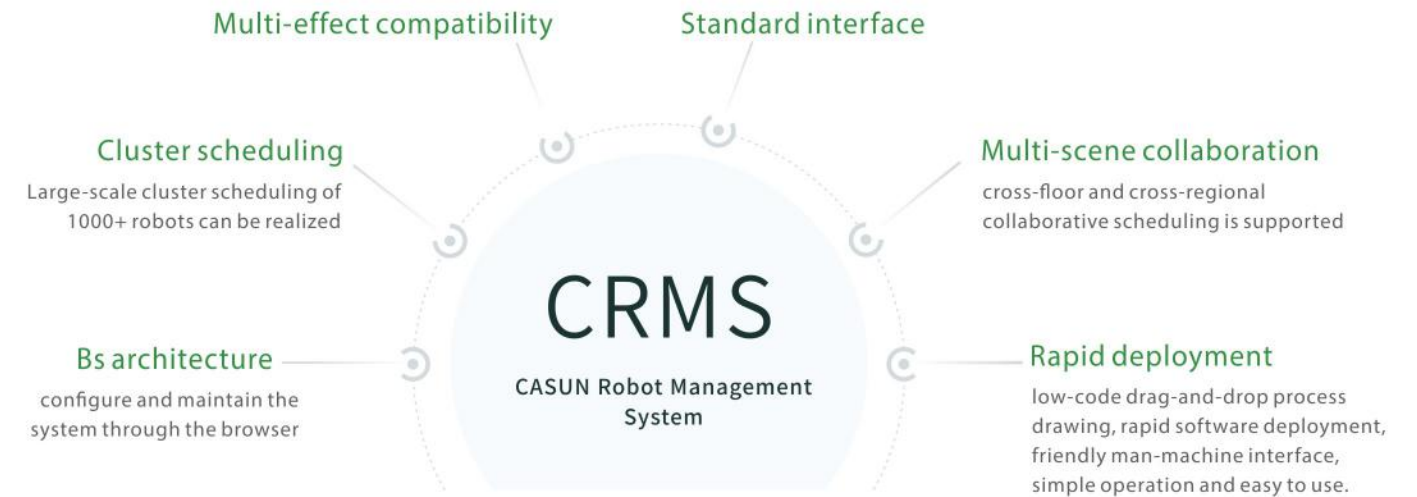

## System Structure

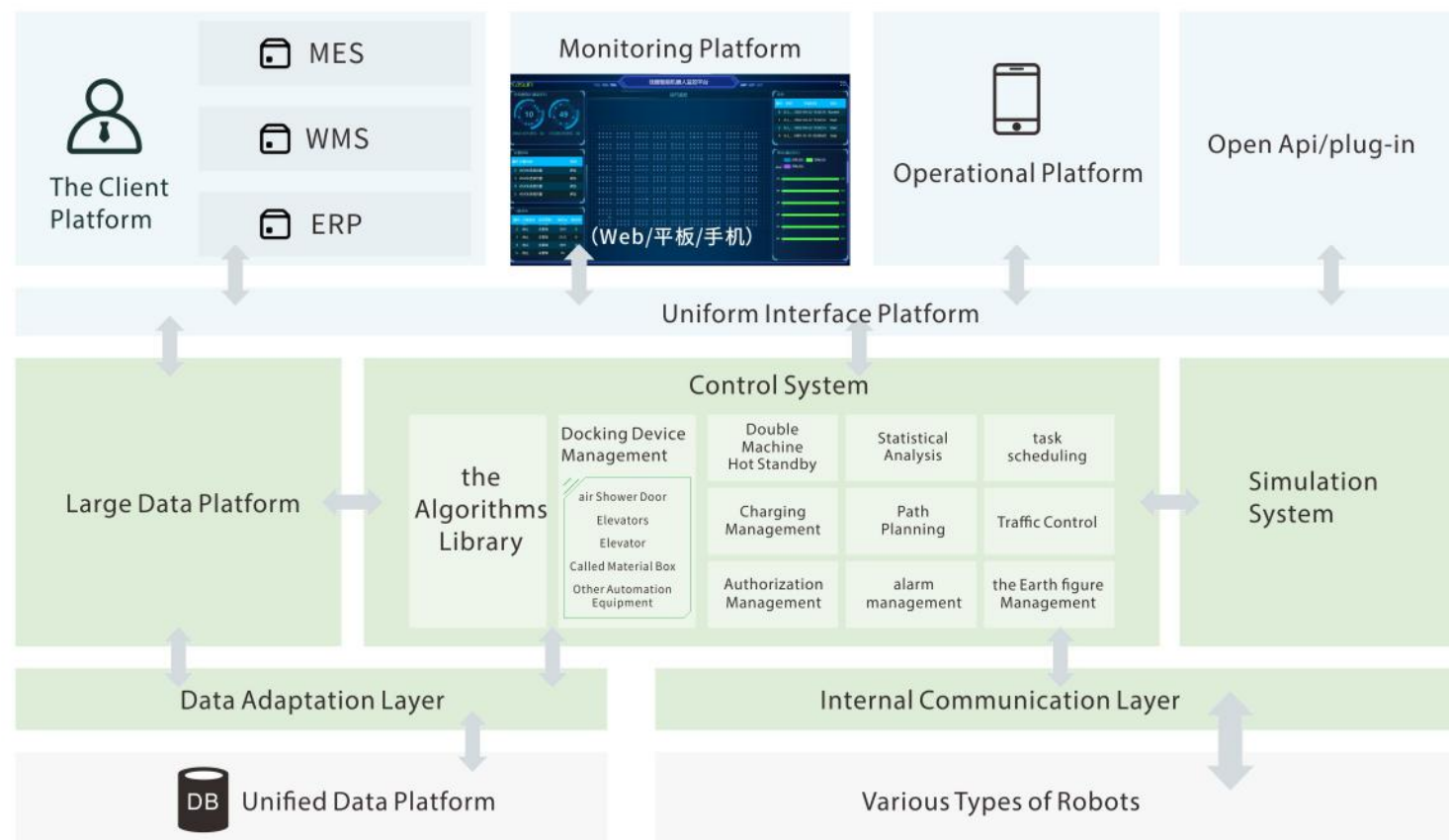

## System Interface

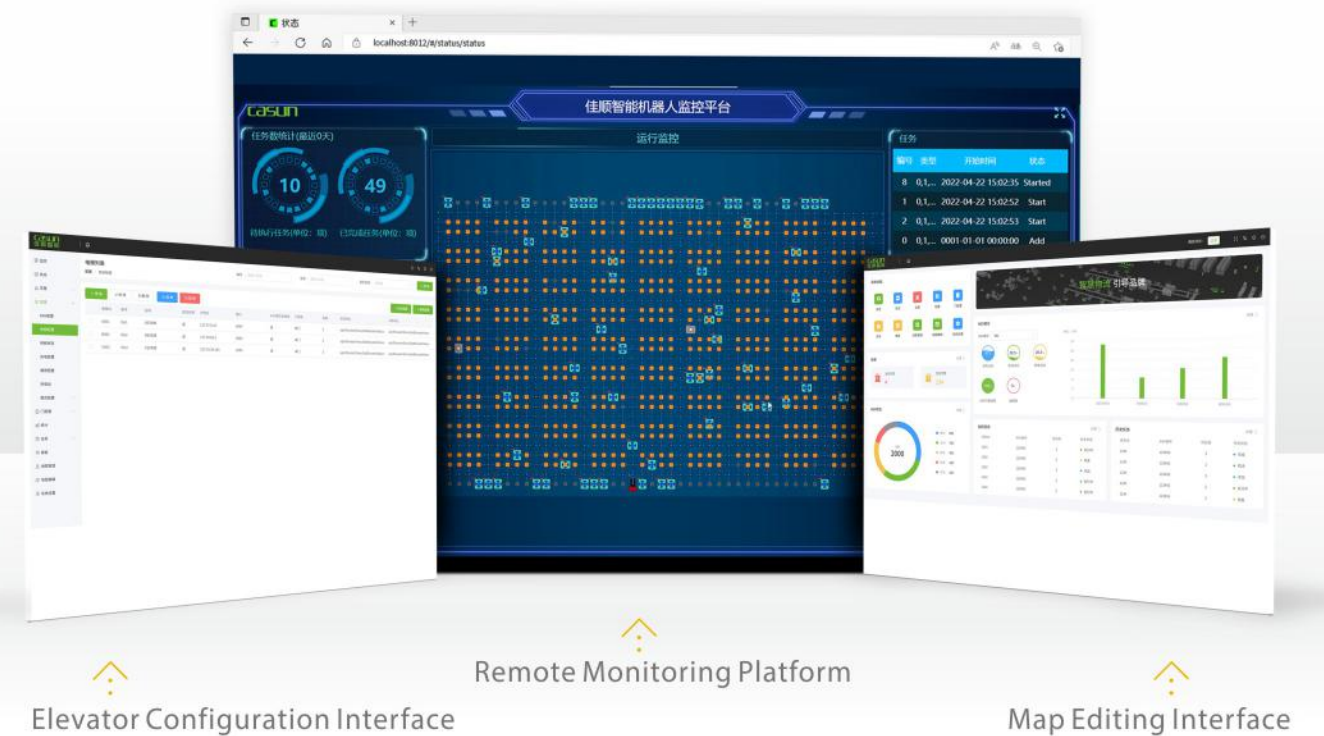

# Intelligent Warehouse Management System

## System Introduction

Intelligent warehouse location management system has the characteristics of flexibility and expansion. Through the effective integration of warehousing functions and mobile robot logistics and transportation links, it provides the overall solution of warehousing management based on intelligent logistics.

## System Feature

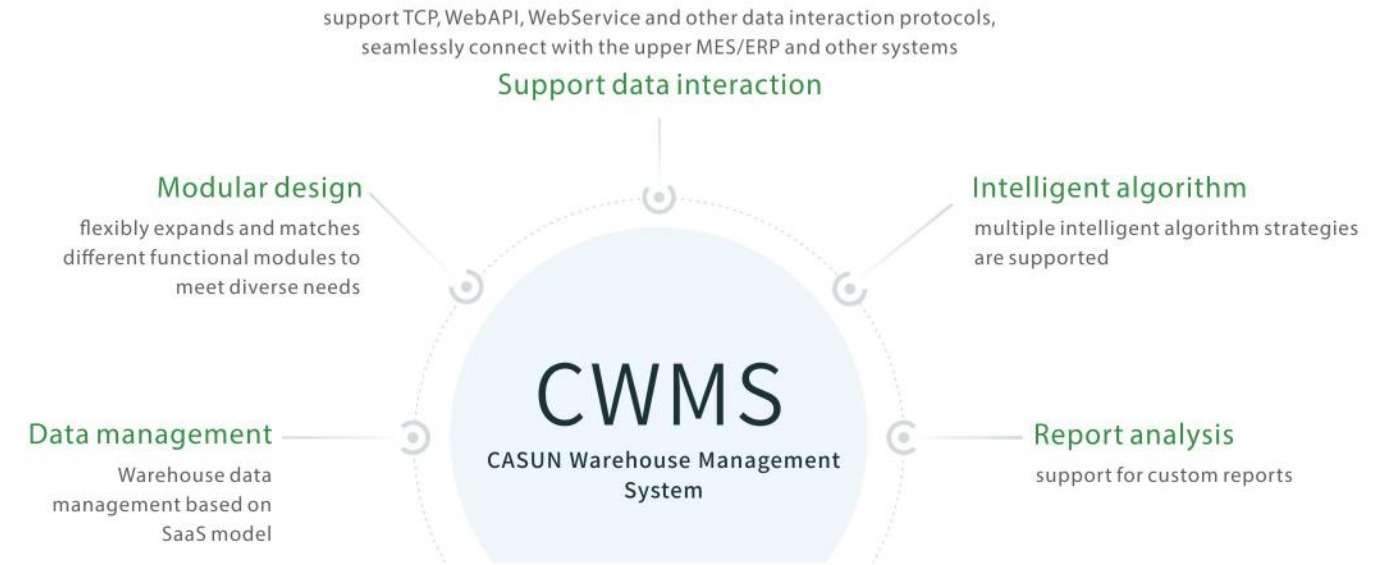

## System Structure

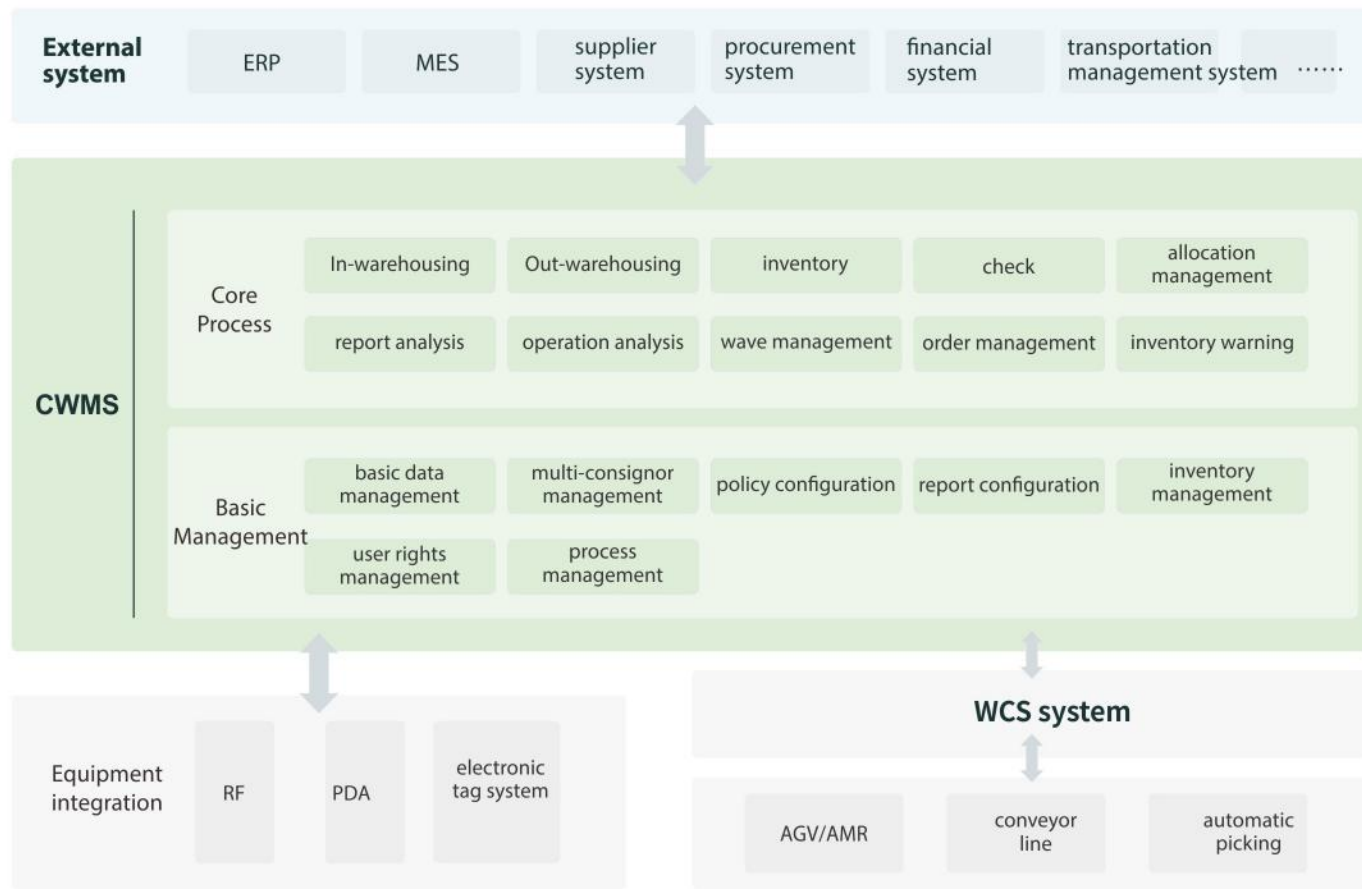

## System Interface

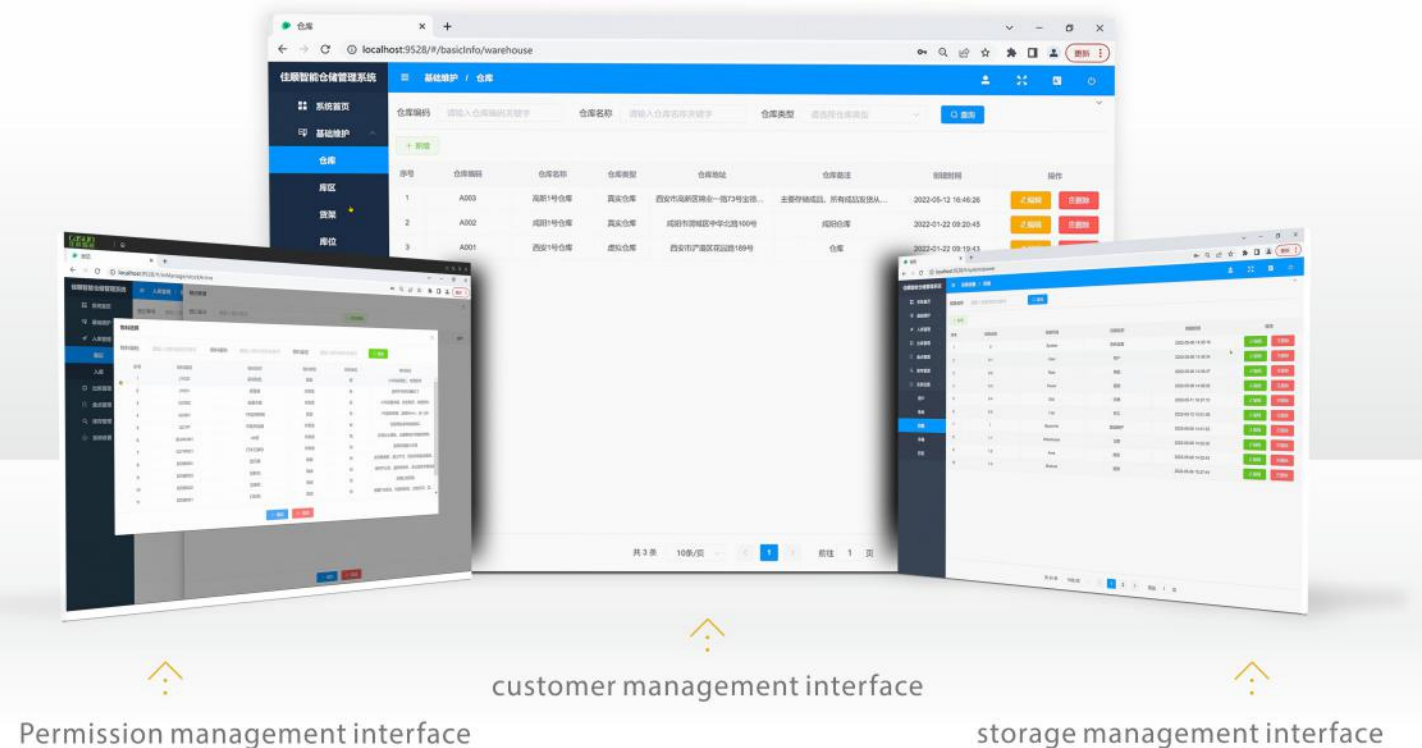

# Intelligent Warehouse Equipment Control System

## System Introduction

Intelligent storage equipment control system is a management control system connecting WMS and intelligent hardware (AGV, conveyor, RFID equipment, etc.). The tasks of the upper layer are decomposed into dispatching instructions and sent to each automatic equipment. Meanwhile, the warehouse operating environment and equipment running status are monitored, and equipment abnormalities are timely warned. Finally, the unified monitoring and scheduling of various automatic equipment in storage is realized, and the automation efficiency is improved.

## System Structure

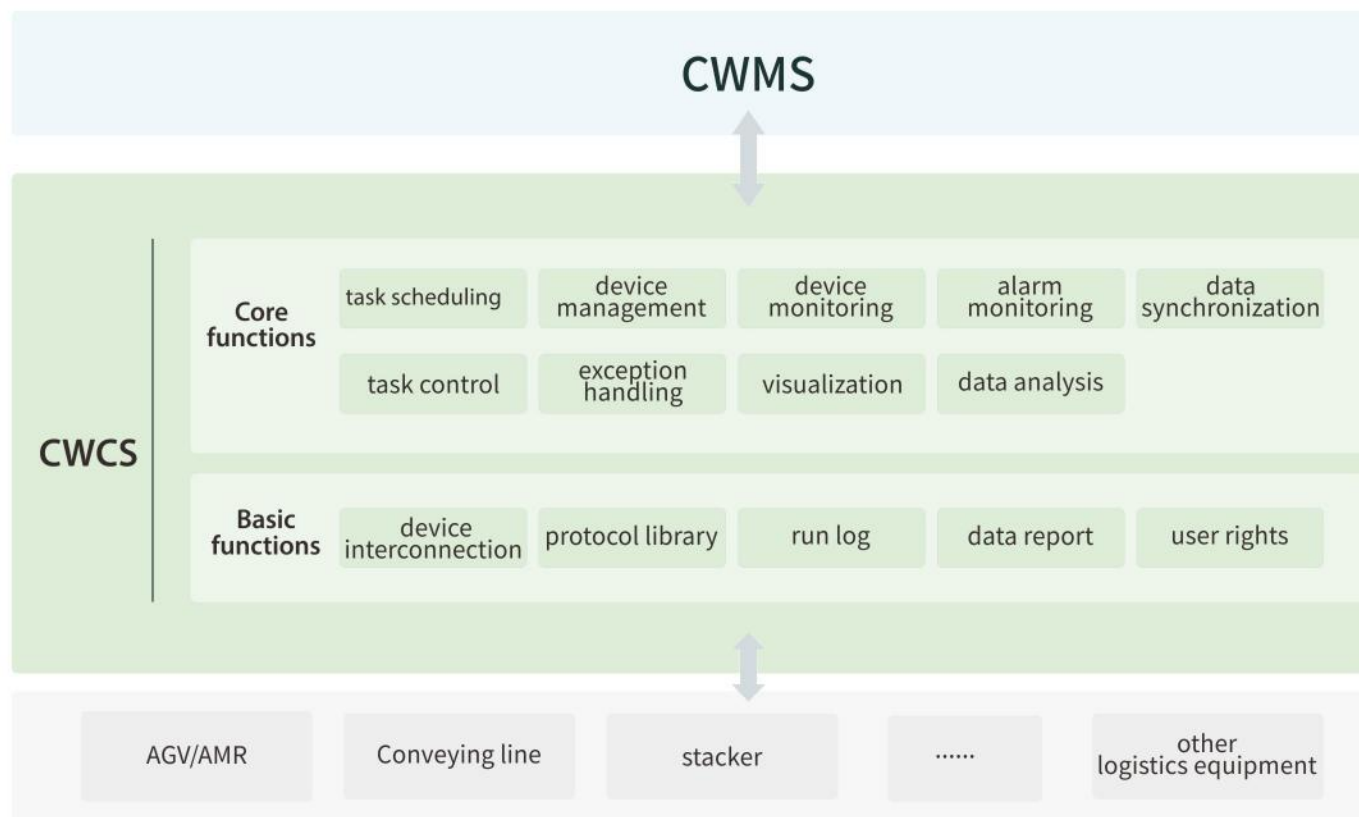

## System Feature



## System Interface

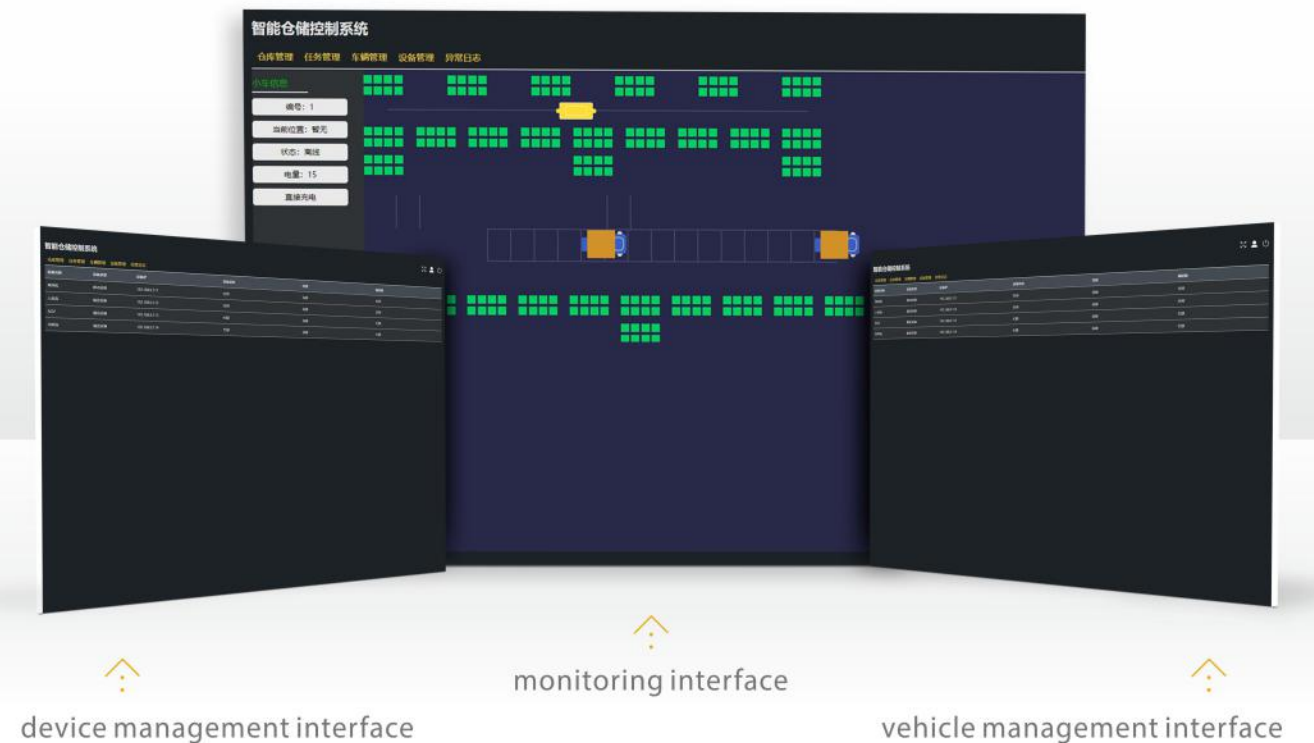



# Intelligent Warehouse Sorting System

## System Introduction

Intelligent warehouse sorting system is a comprehensive solution system for intelligent logistics sorting scenarios. The system combines the AGV control function of management, WCS, WMS basic function, at the same time in intelligent sorting scene have special sorting control system of AGV data through WCS system and WMS data after fusion depth, the prediction of the task and sequence of sorting and evaluation and reasonable dispatching sorting task, implement efficient sorting. It is especially suitable for express e-commerce, warehousing and distribution centers or transport centers in logistics and circulation industry

## System Structure

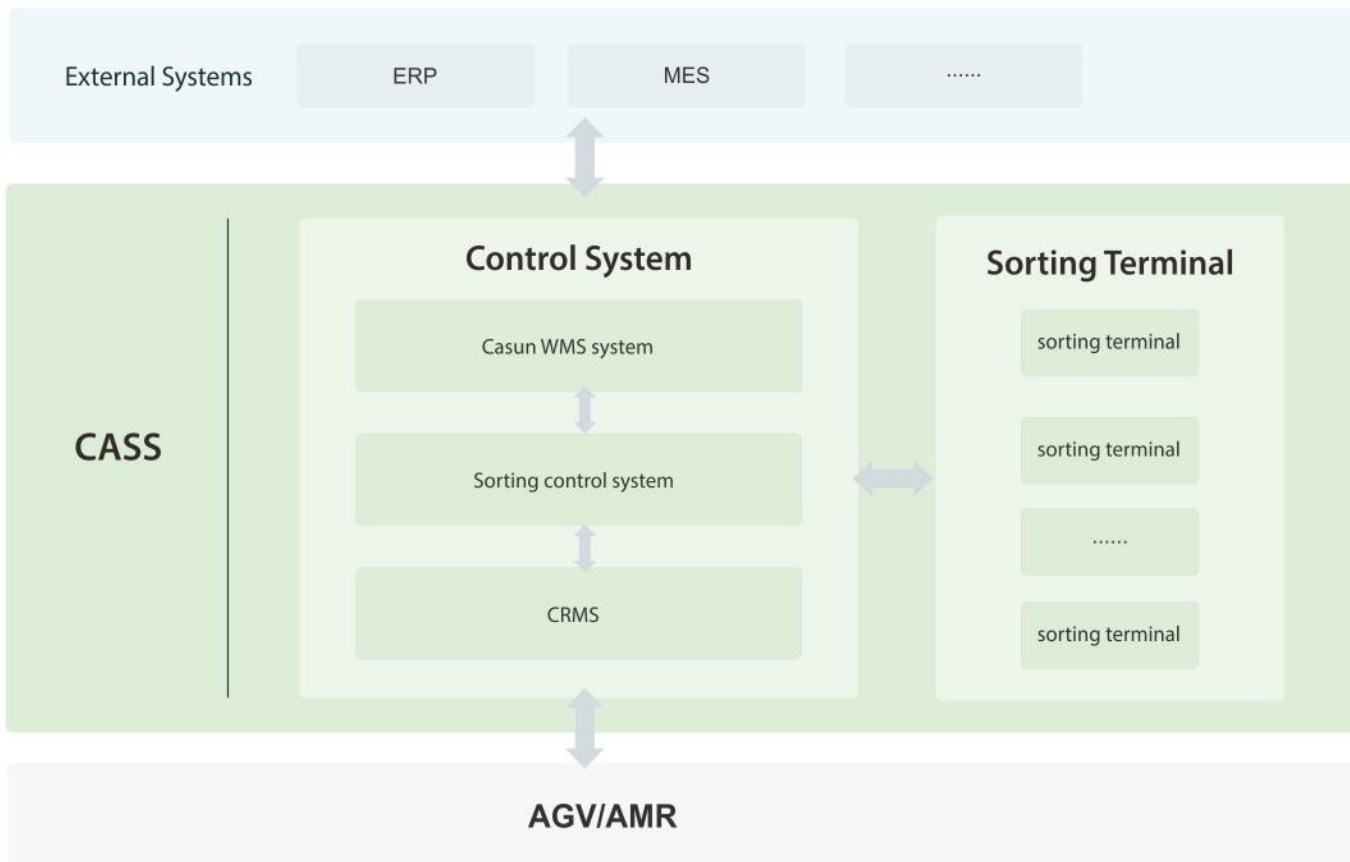

## System Feature



## System Interface



function selection interface

monitoring interface

login interface

# Digital Simulation System

## System Introduction

Casun's digital simulation system can achieve 1:1 simulation of robots. It can not only realize synchronous simulation of robots in real scenes through digital twin technology, but also complete validity verification of the scheme and assist project decision-making through simulation tools of the system in the scheme design stage

## System Structure

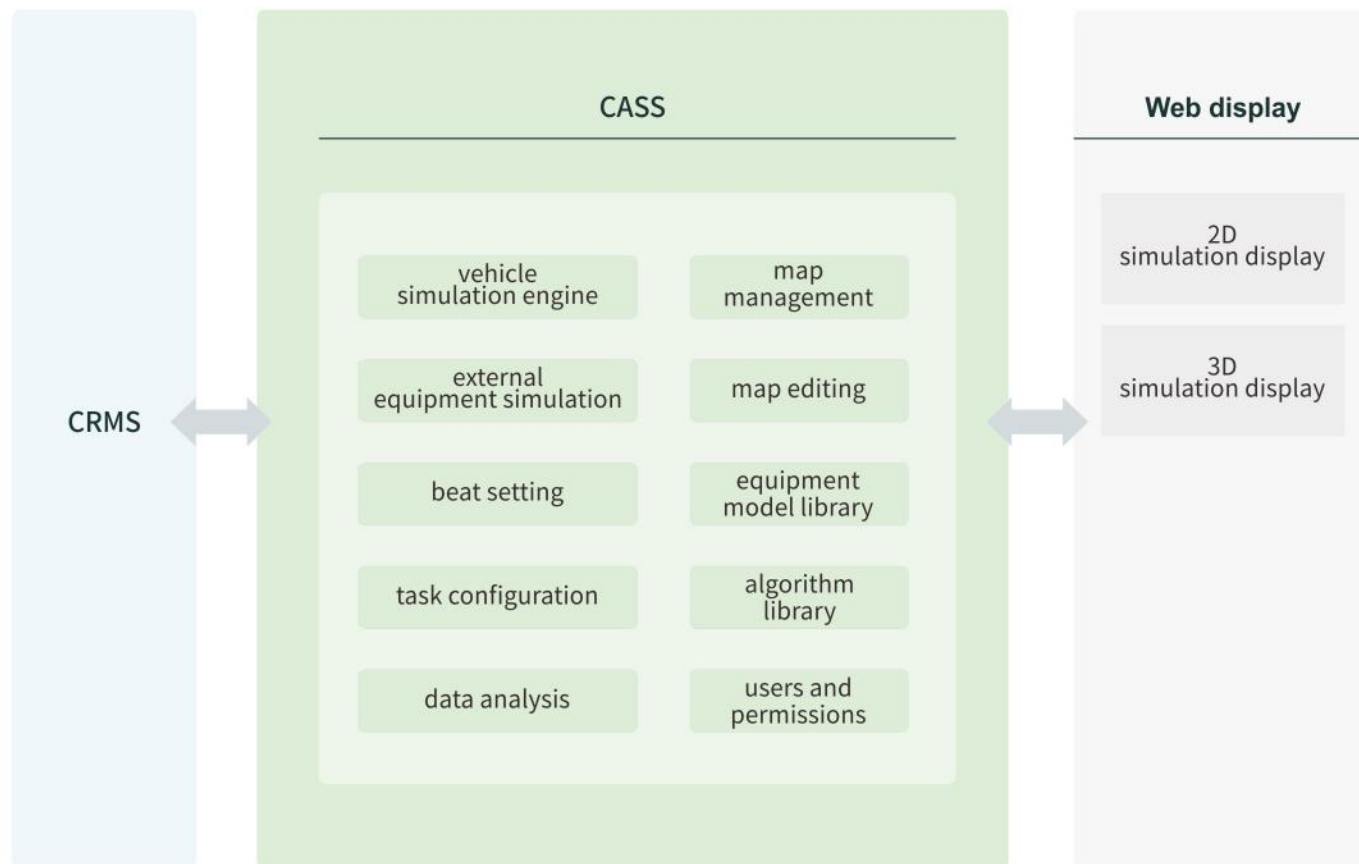

## System Feature



## System Interface



## Requirement points

### Industry Overview

With the rapid growth of the output of new energy electric vehicles, China's lithium battery industry continues to maintain a rapid growth trend, and the industry innovation is accelerating. At the same time, lithium battery manufacturing process from automation to intelligent high-speed transformation. Industrial mobile robot AGV/AMR has been introduced on a large scale to replace the traditional process in the front, middle and rear stages of the process, improve the flexibility and efficiency of the production line, stabilize the quality and delivery time, and form a data closed loop for process tracking.

### Industry trends

- 01 New energy vehicles, low carbon environmental protection requirements and energy crisis push up the development progress of lithium electric industry
- 02 The policies for industry investment and financing are loose, and leading enterprises lead the expansion and expansion strategy
- 03 The popularization of the concept of de-artificialization in logistics operation links and the strong demand for flexible manufacturing
- 04 The mature application of mobile robots in the early, middle and late stages promotes the development of industry standardization

### Partners



Transfer and dock the foil



Pole roll after cutting



Segmented coil transportation

## Smart logistics solution

### Solution advantage

- Improve space utilization rate**  
the space is small, and the introduction of AGV/AMR flexible line can replace the traditional large conveying line
- Flexibility**  
AGV/AMR can complete route and process changes by changing procedures.
- High fault tolerance**  
AGV/AMR has the function of mixed-line transportation
- Fast fault recovery**  
When AGV/AMR fails, they can be restored manually or automatically.

### Economic benefits

- Reduce manpower input **20%**
- Improve production turnover efficiency **20%**
- Investment recovery cycle **1.5-2** Years

### Solution composition



battery assembly & testing



Pack output



Pack storage

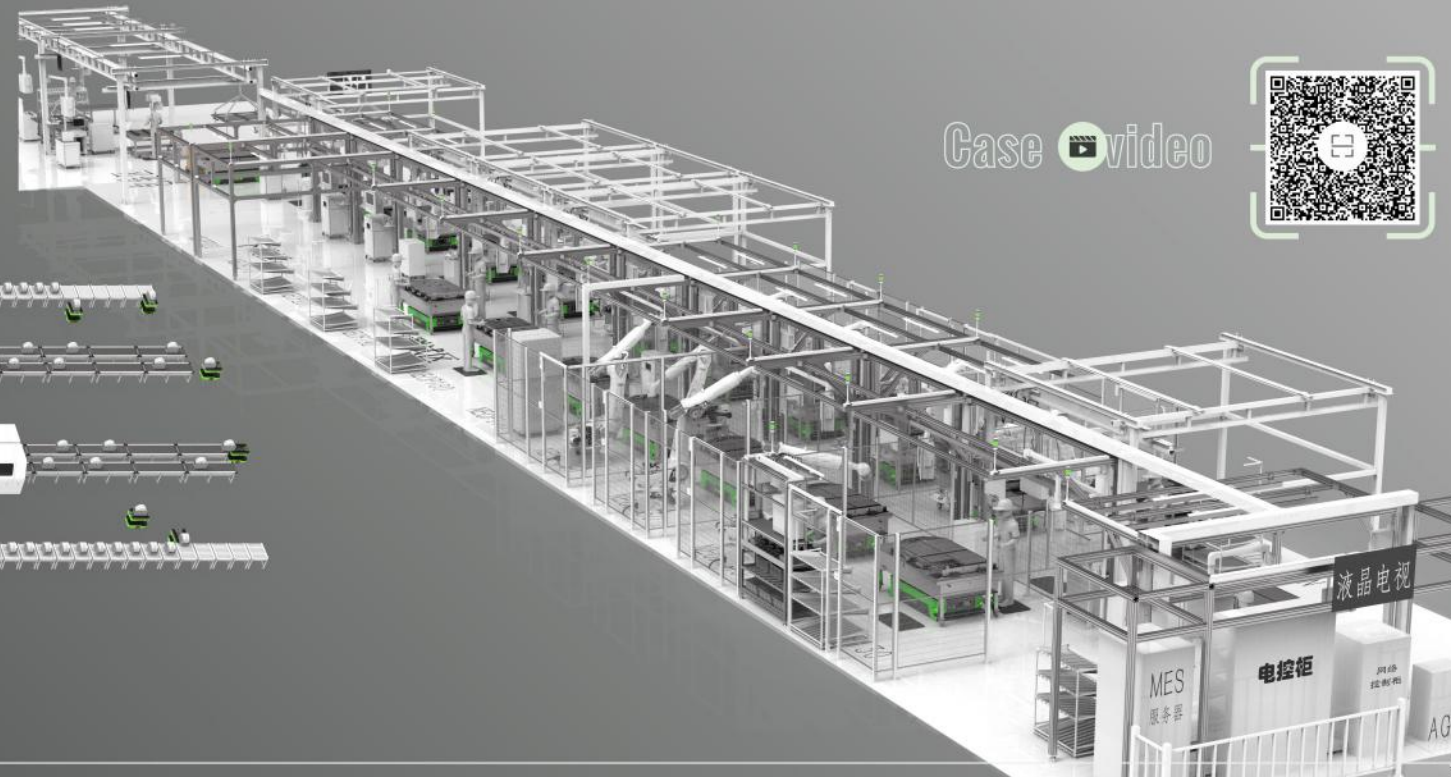

Case video





# NEW ENERGY PHOTOVOLTAIC

## Requirement points

### Industry Overview

With the global fossil energy (oil, coal) increasingly close to exhaustion, climate warming ecological environment, countries around the world on the use of clean energy and carbon emission standards under strict requirements, photovoltaic power generation will become an important channel of energy output. In recent years, the application and development of photovoltaic energy storage technology is advocated vigorously by our country, and the industrial scale is expanded constantly. No matter in core technology, product manufacturing, equipment, or in market development, installation and service, it has a certain industrial chain with independent intellectual property rights, some of which have reached the international leading level. As an essential link in intelligent logistics, mobile robots are widely used in the photovoltaic industry, which greatly reduces the labor cost of logistics transportation and promotes the development of intelligent logistics.

### Industry trends

01 The mobile robot can realize the intelligent transportation of the photovoltaic industry's materials automatically on/off the line and in the middle of the transfer, and realize the unmanned automatic transportation;

02 Intelligent transportation also has systematic management, data traceability, improve management level;

03 By means of multi-system connection and integration, it can solve the problems of accuracy and efficiency of material transportation in each production line.



FoldingA of incoming battery material



Battery fleece technology



Battery etching technology

## Smart logistics solution

### Solution advantage

enhance productivity  
Automatic transfer of multiple production processes, efficient completion of transportation tasks.

intelligentize  
Improve the degree of intelligence, realize intelligent logistics.

Reduce labor intensity of personnel  
Automatic delivery of heavy materials to work stations.

### Economic benefits

Reduce manpower input **30%**

Improve production turnover efficiency **20%**

Investment recovery cycle **1.5-2** Years

### Solution composition



Automatic transfer in process shop



Battery coating technology



Battery laser technology

Case video



### Partenr

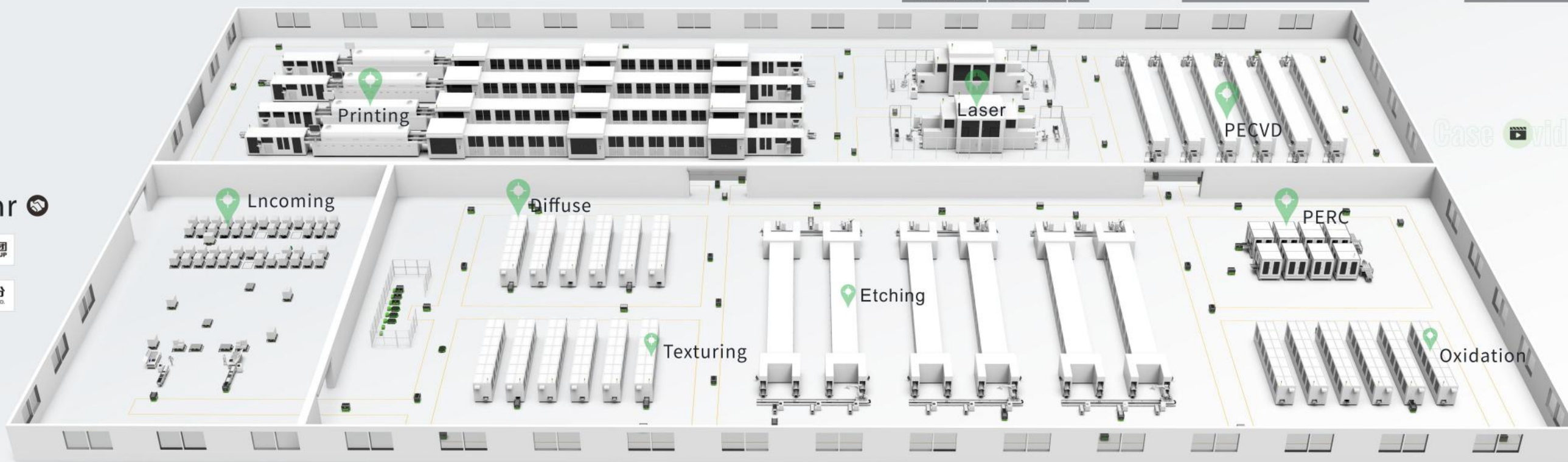



## Requirement points

### Industry Overview

Under the background of electric and intelligent automobile, domestic automobile manufacturers have begun to carry out transformation and upgrading of flexibility, agility, intelligence and information technology. As a standard configuration to achieve flexible manufacturing and flexible assembly, mobile robots play an important role in the automobile and parts industry, helping the industry logistics upgrade from automation to intellectualization.

### Industry trends

- 01 The production process of automobile industry is fixed, with high degree of standardization and automation, and intelligent transformation is convenient
- 02 The automotive industry has more than 10 years of experience in the use of mobile robots, and AGV/AMR has become a standard equipment
- 03 The overall production capacity of the automobile industry is high, and the demand for industrial mobile robots is large
- 04 Improve the automation and flexibility of entire automobile manufactures and improve per capita efficiency

## Smart logistics solution

**Solution advantage**

- Improve production efficiency automatically and efficiently fulfill capacity requirements
- Improve the degree of automation realize intelligent logistics and flexible manufacturing to meet the needs of personalized customization.
- Reduce labor intensity automatically send heavy materials to work stations

**Economic benefits**

- 20%** Optimize and reduce stock preparation and replenishment employees by more than
- 100%** The accuracy rate of outbound shipments can be improved to
- 100%** Timely rate for supply of parts to the production line can reach to
- 20%** Reduce the area of warehouse management by more than



SPS trolley automatically on-line



SPS aggregation and distribution area to take material



SPS empty box return



assembly parts batch distribution

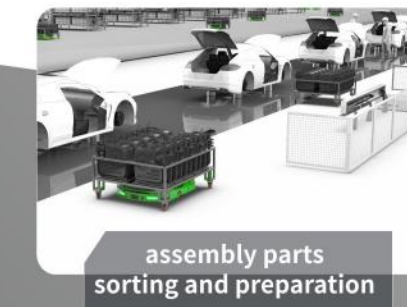

assembly parts sorting and preparation



empty trolley return

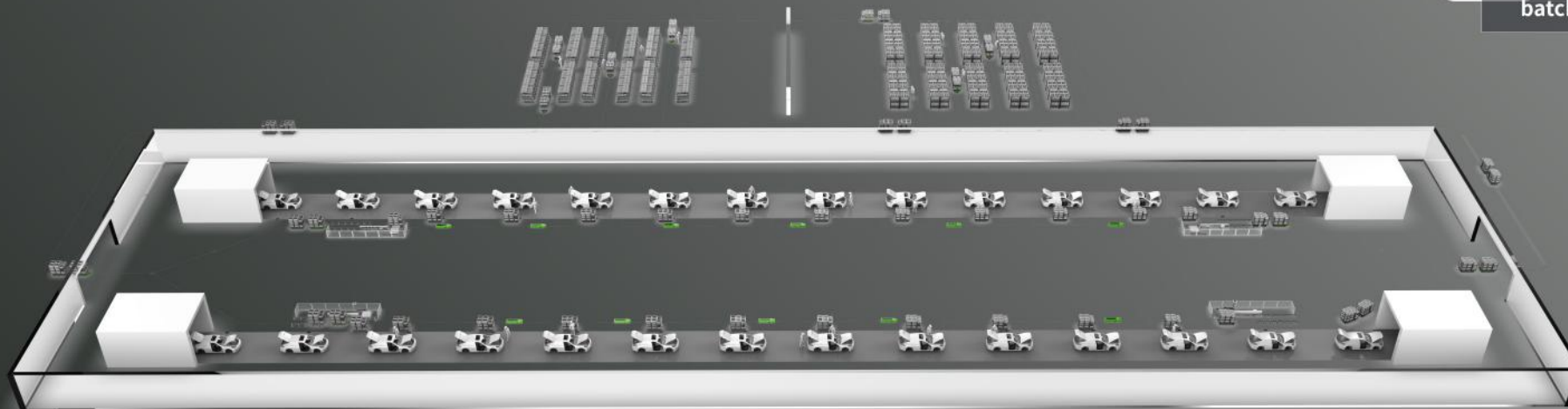

Partner

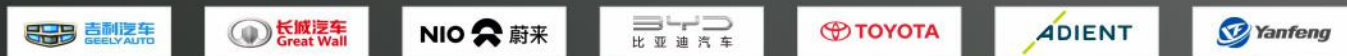

Case video





# FLAT PANEL DISPLAY INDUSTRY

## Requirement points

### Industry Overview

The increasing consumer market stimulates the domestic flat panel display industry to develop towards the direction of large screen size and diversified functions. The panel design is diverse, the process is complex, the cross-line production switch is frequent, and the flexible production of enterprises requires the production line data information flow to be higher and higher. AGV/AMR gives the answer to intelligent production and transportation, enabling flat panel display enterprises to provide intelligent logistics comprehensive solutions

### Industry trends

- 01 Panel sizes are different. Micro LED and Mini LED have become the mainstream trend.
- 02 Different needs of vehicle, wearable, home appliances and industrial applications are the trend of personalized customization.
- 03 The process of different products is different, and cross-line production is frequently switched. Flexible production has become the general trend.
- 04 The types of raw materials are increasingly complex, and the requirements for fine management of warehousing and logistics are increasingly high.
- 05 Increasing labor costs make management more difficult



Transshipment of semi-finished products across floors



The POL offline to transport to the warehouse



Polarizer ATL transport



Polarizer ABL transport



Polarizer DAL online

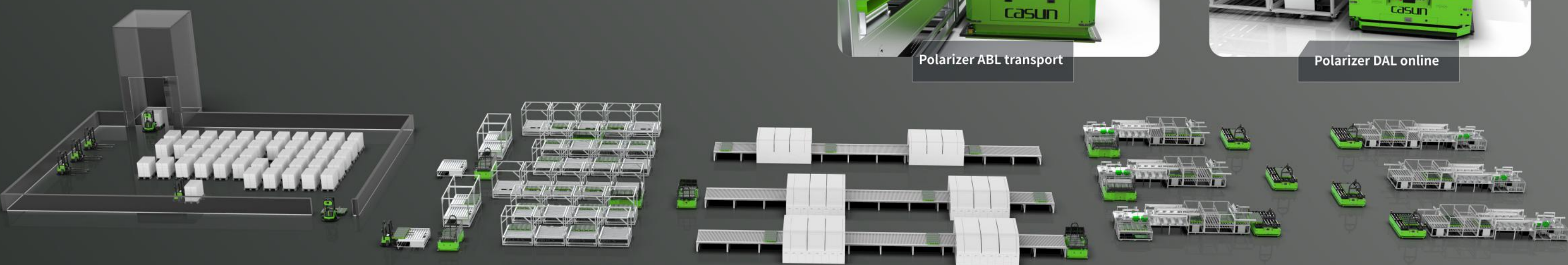

## Smart logistics solution

### Solution advantage

- Real-time data monitoring**  
the status of material information can be reported in real time to ensure the integrity of the data chain and form a closed data loop.
- Flexible process connection**  
cutting machine quickly, making production scheduling more flexible, to meet the diversified production mode.
- Reduce labor cost**  
reduce material damage in the handling process, thus achieving cost reduction and efficiency increase

### Economic benefits

Reduce the operating costs by **26%**

The damage rate of defective materials in the handling process is reduced by **90%**

### Solution composition



### Partner



Case video





# 3C AND SEMICONDUCTOR INDUSTRY

## Requirement points

### Industry Overview

With the development of "individual media", the extension of online services, and the trend of personalized and private consumption have continuously upgraded the demand for 3C products in China. Manufacturers in all aspects of the 3C field have an urgent demand for automatic transformation, and flexible assembly lines and intelligent three-dimensional warehouses have entered a stage of rapid development. The huge annual output value and volume of 3C electronics industry provide a huge market capacity for mobile robots; The contradiction between a large number of labor needs and recruitment difficulties promotes the intelligent upgrading of the whole industry.

### Industry trends

01 3C electronics needs flexible logistics system to realize material transfer between multiple processes, while AGV/AMR can be adjusted timely with the change of production process flow.

02 The low cost and high efficiency of mobile robots can relieve the recruitment pressure caused by the increasing shortage of human resources.

03 Real-time collection and reporting of production process data to solve the problems of precision and efficiency of material transportation in each production line.

## Smart logistics solution

### Solution advantage

**Flexible transportation**  
AGV/AMR can complete route and process changes by changing procedures

**High work efficiency**  
24H uninterrupted work all day to meet the demand of production capacity

**High safety dependence**  
AGV/AMR carrier implements whole-process control with low error rate

### Economic benefits

Save labor force of factory logistics by

40%

Improve the efficiency of picking and distribution in warehouse, and increase the efficiency of picking by

30%

### Solution composition



Cross-floor raw material distribution

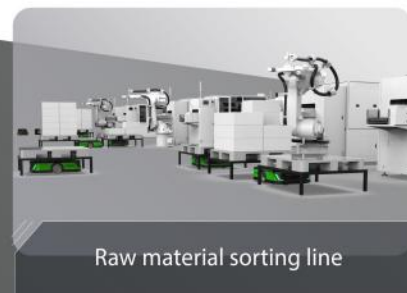

Raw material sorting line



Borderline semi-finished product distribution/caching



Grab the finished product automatically offline



Finished product off line



finished product storage

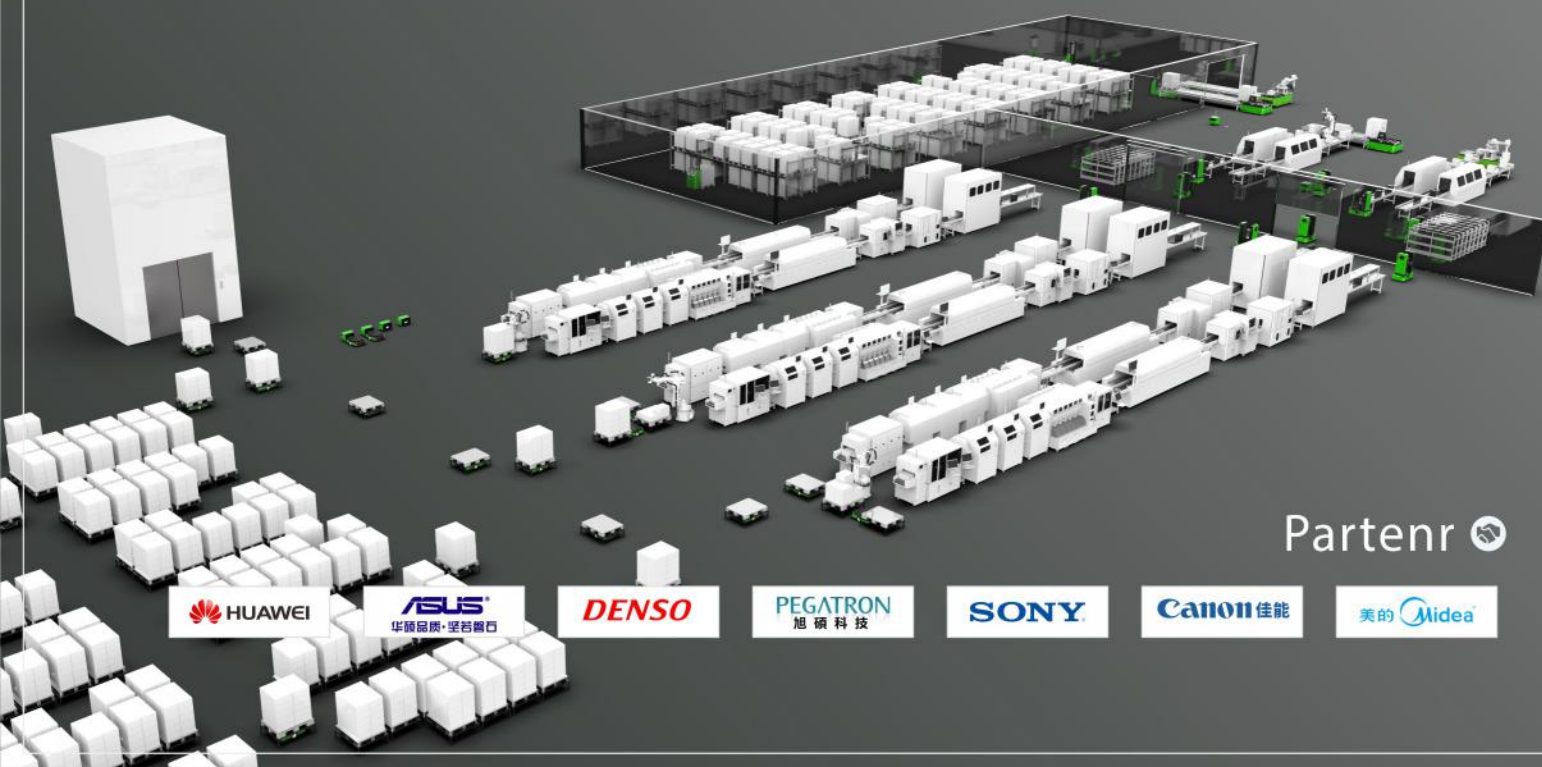

Partner



Case video





## Requirement points

### Industry Overview

In recent years, with the support of national policies, logistics, cold chain fresh distribution and e-commerce logistics are developing rapidly towards intelligent logistics, and the industry is placing more emphasis on operational efficiency and benefit. As an essential part of intelligent logistics, mobile robots are widely used in the logistics industry, which greatly reduces the labor cost of the logistics circulation industry and promotes the development of intelligent logistics.

### Industry trends

- 01 Logistics robots provide intelligent and unmanned transportation from products to materials, such as automatic on-line, automatic offline, and intermediate transfer, and solve the problem of low efficiency in transportation and sorting of materials
- 02 To meet the industry demand for cost reduction and efficiency increase, fully intelligent management can improve the management level and effectively avoid a series of factors such as inefficient personnel management
- 03 Large volume of business requires data tracking: product data management and material information traceability
- 04 The industry has high requirements for storage capacity. Mobile robots can meet the requirements of narrow tunnels and high shelves for compact storage layout, saving space costs.



Cross-floor raw material distribution



Cross-floor raw material distribution



Cross-floor raw material distribution

## Smart logistics solution

### Solution advantage

**High work efficiency**  
24 hours without shutdown, can intelligently realize loading and unloading materials, independent transportation and intelligent sorting; Multiple scheduling algorithms support different sorting scenarios

**Improve management efficiency**  
realize fully intelligent material flow, dynamic prediction, storage location heat statistics and management

**High reliability**  
the whole process is recorded, tracked and retrieved to reduce the frequency of misoperation

### Economic benefits

Increase space utilization rate by **40%**

Increase the overall inspection and checking capacity by **30%**

### Solution composition

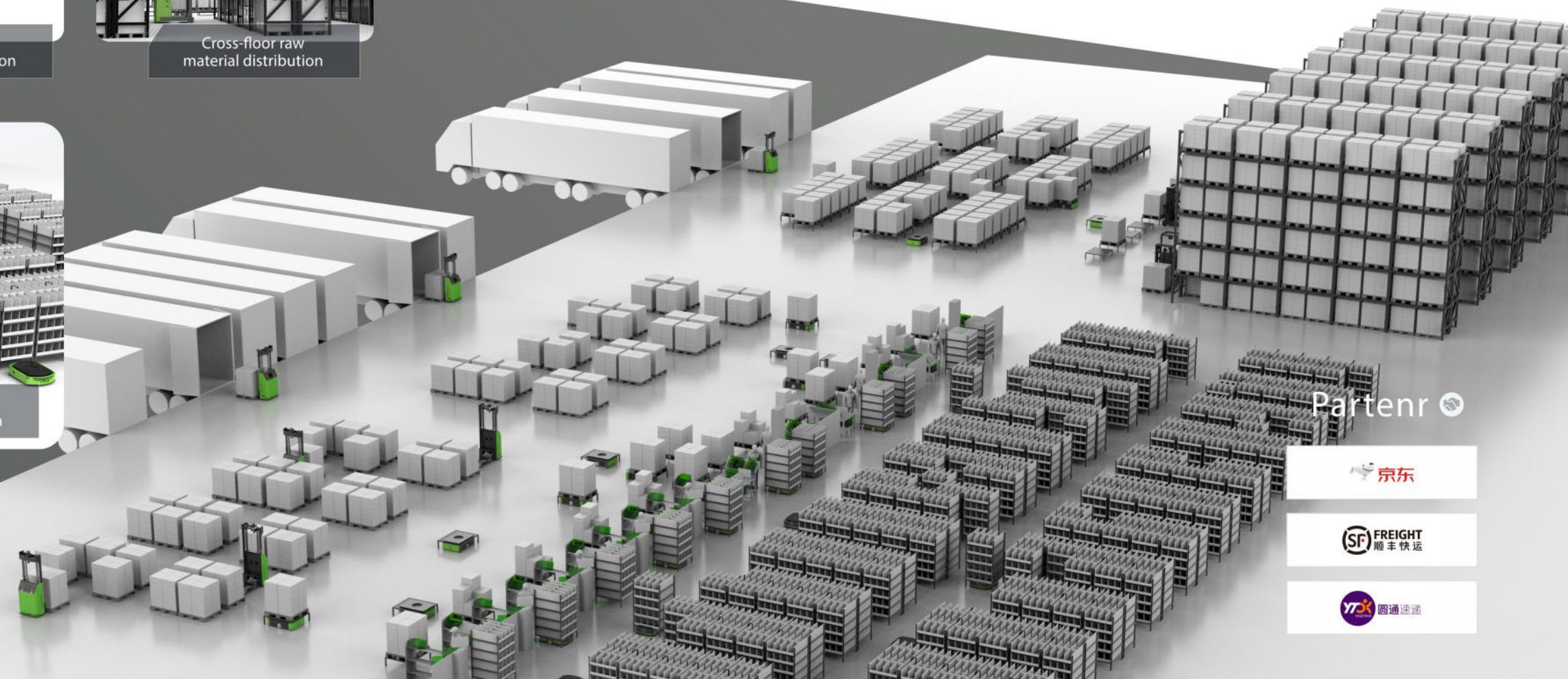

Partner



Case video





**SPECIALTY**



**EFFICIENT**



**HIGH QUALITY**

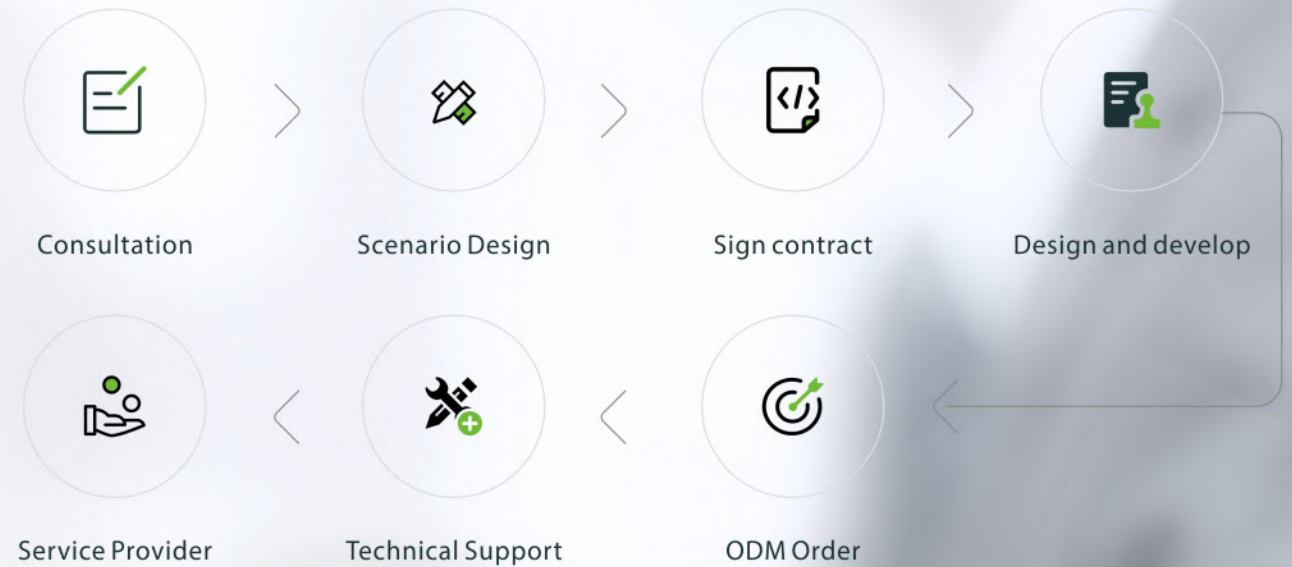

**Pre-sale**

**Product consulting**

General/custom product function and selection recommendation

**Product planning**

Site investigation, scheme design, process planning.

**System design**

Control system design and development



**Sale**

**Product customization**

Production and development of customized products

**System development**

Software development deployment

**Installation**

Software and hardware Deployment



**After sales**

**Training**

Product/system maintenance training

**Operating services**

Mobile robot management and maintenance

**Maintenance service**

After-sales support, regular inspection, 7\*24 hours customer service consultation

website



WeChat



Service Official Account

other



Tiktok

Download



video account



Toutiao